



A1040 MIRA 3D

Ultrasonic low-frequency tomograph

Operation manual

Revision 2.0.0

Acoustic Control Systems - ACS Group
Saarbrücken, Germany 2022

This instruction manual contains essential information on how to use this ACS product safely and effectively. Before using this product, thoroughly review this instruction manual. Use the product as instructed.

1. Cover Page Back	5
2. Cover Page Front	6
3. Important basic information	7
4. Abbreviations	9
5. Lables, position and content	10
6. Scope of Delivery	12
6.1 A1040 MIRA 3D	12
6.2 A1040 MIRA 3D PRO	13
7. Main Components	17
8. Keys and system LEDs	20
9. Rechagreable Battery of the Main Device	23
10. Rechargeable Battery of the Control Unit	26
11. Device usage and Limitations	30
12. Safety	33
13. Maintenance and Repair	35
14. Technical Specification	38
15. Operation	39
16. Trouble shooting	43
17. CE Certificate	47
18. B-Scan	48
18.1 Information panel	48
18.2 Main parameters	48
18.3 Display parameters	50
18.4 File manager	52
19. MAP	57
19.1 Information panel	57
19.2 Main parameters	57

19.3	Display parameters	58
19.4	File manager	58
19.5	MAP manager	58
20.	C-Det	60
21.	A-Scan	63
21.1	Farm View: A1048 MIRA 3D	65
21.2	Farm View: A1048 MIRA 3D PRO	68
22.	Reporting	69
23.	Setup	72
23.1	Instrument configuration	75
23.1.1	A1040 MIRA 3D	75
23.1.2	A1040 MIRA 3D PRO	77
23.2	Automatic transducer testing	79
23.2.1	A1040 MIRA 3D	79
23.2.2	A1040 MIRA 3D PRO	81
24.	Powering	82
25.	Connectivity	85
25.1	WiFi access point concept	85
25.2	WiFi configuration of a master	85
25.3	WiFi configuration of a slave	88
25.4	WiFi module firmware update	90
25.5	Migration from Hotspot to WiFi	94
26.	Getting started	98
26.1	Preparation for work	98
26.2	Update	99
26.3	App installation	101
26.4	App activation	102
27.	Licensing	105
28.	File format	108
28.1	File list	108
28.2	Modes	111
28.3	Raw data	111

29. Downloads	116
29.1 Tutorials	116
29.2 Files	116
30. Instrument tuning	117
30.1 Analog gain	117
30.2 Time gain compensation	118
30.3 Software time gain compensation	120
30.4 Operating frequency	121
30.5 Transmitter pulse sequence	122
30.6 Velocity calibration	123
30.7 E-Boosting	125
Index	0

1 Cover Page Back



Service Address: ACS-Solutions GmbH
Science Park 2
66123 Saarbrücken
Germany
Phone: +49 (0) 681 9659 2270
Fax: 49 (0) 681 9659 2280
E-Mail: info@acs-international.com
Web: acs-international.com

2 Cover Page Front

A1040 Mira 3D

ULTRASONIC LOW-FREQUENCY TOMOGRAPH

User Manual



This manual contains important information about the correct and safe use of the device.

Read this manual carefully before using the device for the first time and use the device only in the intended manner.

Always keep this manual in the vicinity of the device.

Revision: 1

Issued: November, 18 th 2020



CAUTION

Make sure the manual on hand corresponds with the currently installed firmware and control software release on your system.

Check the firmware and control software release that is currently installed on your system (for further information see chapter "[Setup](#)")⁷²

With every firmware and control software update the functionality of the device will change. It is possible that formerly described functions are not available any more, new functions are added or pictograms and/or procedures change. These changes will be documented in the latest, online available manual.

Check [page](#)⁹⁹ for available manuals and software updates.

3 Important basic information

Read this manual carefully before using the device to ensure safe and proper use.

Intended use:

The A1040 MIRA3D device is intended for the ultrasonic inspection of constructions made of concrete, reinforced concrete and stone with one-sided access. The design is for manual operation. For positioning purposes, the device is equipped with 4 positioning Laser-LEDs class 2M.



WARNING

Never Use the device for any other purposes than stated above. Never use the device on humans or animals. Never look into the Lasers. For further Safety instructions see chapter Safety

The A1040 MIRA3D device must be connected via hotspot to a Control Unit. Only use Control Units approved by ACS for this purposes.



CAUTION

A1040 Mira 3D is normally equipped with a tablet device as Control Unit that is seated in a specially developed housing. The Control Units provided by ACS are selected to guarantee a save and reliable operation of the all over system. Please do not try to open the provided Housing for the control unit. If the control Unit is damaged or malfunctioning, please contact your ACS support.



WARNING

Do not try to control the A1040 Mira 3D with other mobile devices that are not specified and provided by ACS, even if the connectivity and capability of executing the control software seems given. This may result in unexpected behavior, personal injury, and / or equipment damage including impairment of safety. ACS is not liable for any damage or loss (whether contractually or unauthorized, including negligence) caused by not following this warning.

This A1040 Mira 3D is CE-certified according to 2014/30/EU (EMC).



Liquid ingress protection and solid particle protection of the casing is in conformity with level IP53 (standard EN 60529), so the equipment is splash proof and protected against dust.

Despite the IP classification, it is possible that the device will be damaged in certain situations.

Follow the instructions below to maintain water resistance and dust protection.

- Never immerse the equipment into water.
- After contact with clear water, wipe it thoroughly with a clean soft cloth.
- Contact of the device with liquids other than water may adversely affect the performance and appearance of the device.
- Dropping the device may affect the device protection.
- The device should never be opened by untrained personnel.

Safety symbols used in this Manual:

Symbol	Description
 <div style="background-color: black; color: white; padding: 2px; display: inline-block; margin-left: 10px;">WARNING</div>	Indicates a potential threat. Failure to avoid it can result in death or serious injury.
 <div style="background-color: black; color: white; padding: 2px; display: inline-block; margin-left: 10px;">CAUTION</div>	Indicates a potential threat. Failure to avoid it may result in minor injury.
<div style="border: 1px solid black; padding: 2px; display: inline-block;">IMPORTANT</div>	Indicates a potentially harmful situation. If it is not avoided, the device or something in its vicinity may be damaged.





4 Abbreviations

Geben Sie hier den Text ein.

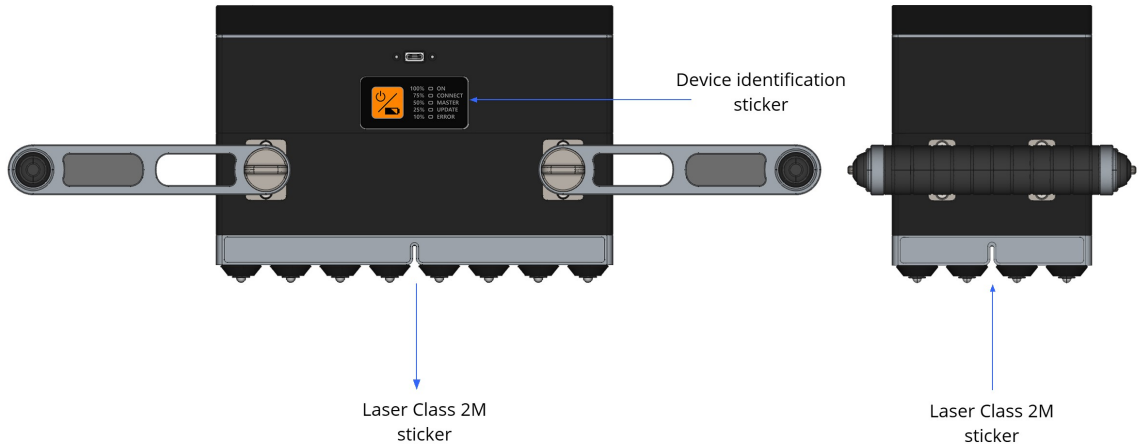
5 Lables, position and content

Labels are safety related and must be present at all time when the device is in use.
Labels are positioned according the Figures ?? below.



Description	Content
device identification Sticker	 <p>Device Name: A1040 MIRA 3D</p> <p>Manufacturer: Acoustic Control Systems-ACS Group</p> <p>Manufacturer Homepage Address: ACS-Interantiona.com</p> <p>Country of origin: Made in Germany</p> <p>CE: Conformity declaration for applicable European Directives</p> <p>FCC: Conformity declaration for requirements of the Federal Communications Commission (FCC) -relevant for delivery, sales and import to USA.</p> <p> Sign or "Read manual first"</p> <p> WEEE symbol that the product contains batteries. These must be collected and disposed of separately according the regional laws.</p> <p>S/N: Serial number of the Device beginning with 120 followed by 5 digits.</p>
Laser class 2 M	 <p>Warning sign placed on the exiting points of all 4 Laser-Diodes. Please see chapter "Safety" for further Detail</p>

6 Scope of Delivery

The following two sections describe the scope of delivery and assembly instructions for A1040 MIRA 3D and A1040 MIRA 3D PRO.

6.1 A1040 MIRA 3D

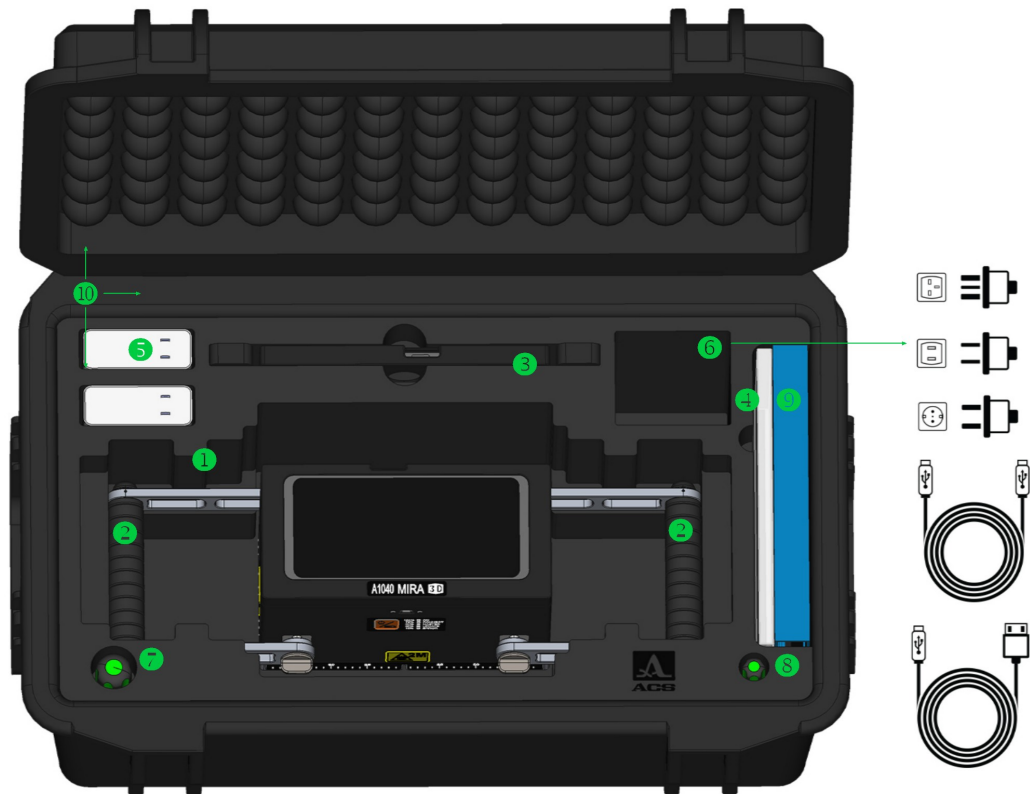

A1040 MIRA 3D Scope of delivery

Part	Amount	Location
Electronic unit A1040 MIRA 3D with 32 x A-DPC® transducers	1	①
Adjustable handle	2	②
Tablet-PC with protective case	1	③
Reference block for functional tests	1	④
Exchangeable Li-Ion accumulator	6	inside of the electronic unit
Power charger	1	⑤
Interchangeable power plugs (US/UK/EU)	3	in the pocket ⑥, 2xUS, 2xUK and 2xEU
Power USB-C cable	1	in the pocket ⑥
USB-A to USB-C cable	1	in the pocket ⑥

Screwdriver Hex-Plus 4.0	1	7
Screwdriver Hex-Plus 2.0	1	8
Cardboard box for documentation	1	9
Warranty certificate	1	inside of cardboard
Operating Manual	1	inside case 10
Hard case with custom foam inlay	1	10

6.2 A1040 MIRA 3D PRO

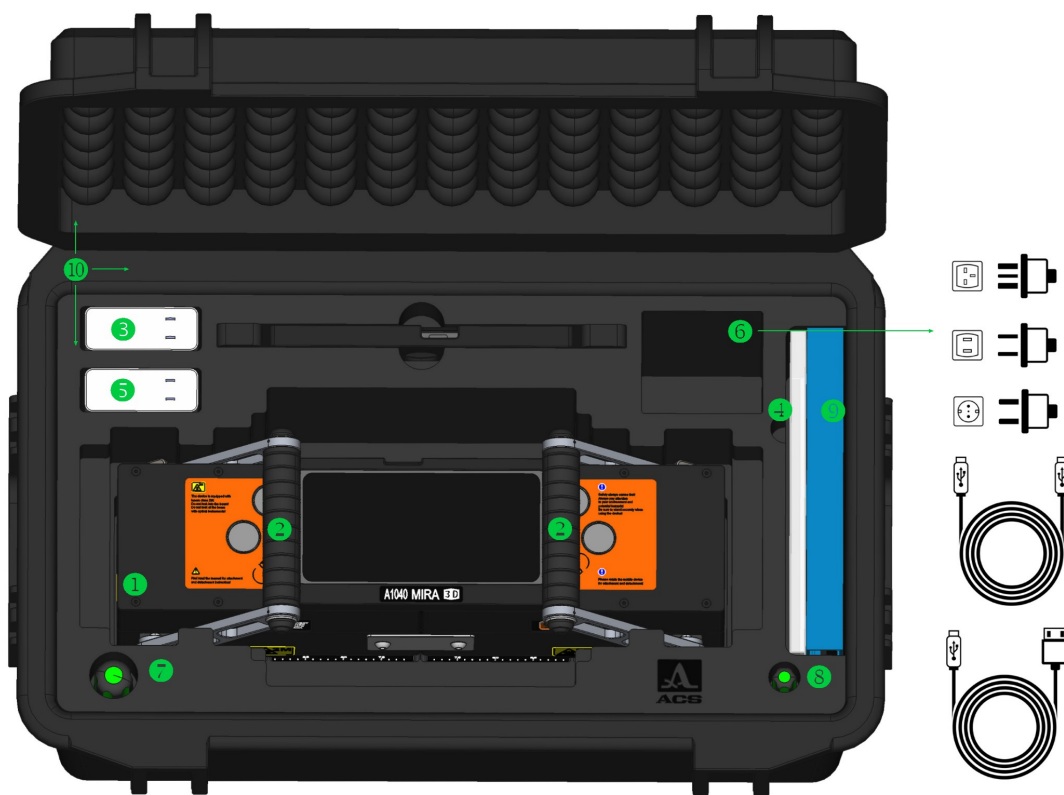

Figure 1: Scope of delivery

A1040 MIRA 3D PRO Scope of delivery

Part	Amount	Location
Electronic unit A1040 MIRA 3D with 32 x A-DPC® transducers	2	1
Adjustable handle	2	2
Tablet-PC with protective case	1	3

Reference block for functional tests	1	④
Exchangeable Li-Ion accumulator	12	inside the electronic unit
Power charger	2	⑤
Interchangeable power plugs (US/UK/EU)	6	inside the pocket ⑥, 2xUS, 2xUK and 2xEU
Power USB-C cable	2	inside the pocket ⑥
USB-A to USB-C cable	1	inside the pocket ⑥
Screwdriver Hex-Plus 4.0	1	⑦
Screwdriver Hex-Plus 2.0	1	⑧
Cardboard box for documentation	1	⑨
Warranty certificate	1	inside the cardboard box ⑨
Operating Manual	1	inside the case ⑩
H-Fastener	2	refer to ② on Figure 3
A2 M6x10 stainless screw	4	refer to ① on Figure 3
Hard case with foam inlay	1	⑩

Electronic units

The A1040 MIRA 3D PRO has two electronic units. These are the master M (also called *primary unit*) and the slave S (also called a *secondary unit*). Usually, the serial number of the master is less than then the serial number of the slave. Check you warranty [certificate](#)^[105] for detailed information. Use the master and slave according to the licensing [policy](#)^[105].

Assemble the A1040 MIRA 3D PRO

The A1040 MIRA 3D PRO tomograph leaves the factory fully assembled. Follow up the given procedure to prepare a master to work as a stand-alone tomograph.

- Put the A1040 MIRA 3D PRO on the flat stable surface. The transducers lay on the surface.
- Detach the Tablet-PC
- Unscrew four screws ① on the both sides of the tomograph, use the screwdriver Hex-Plus 4.0 for unscrewing.

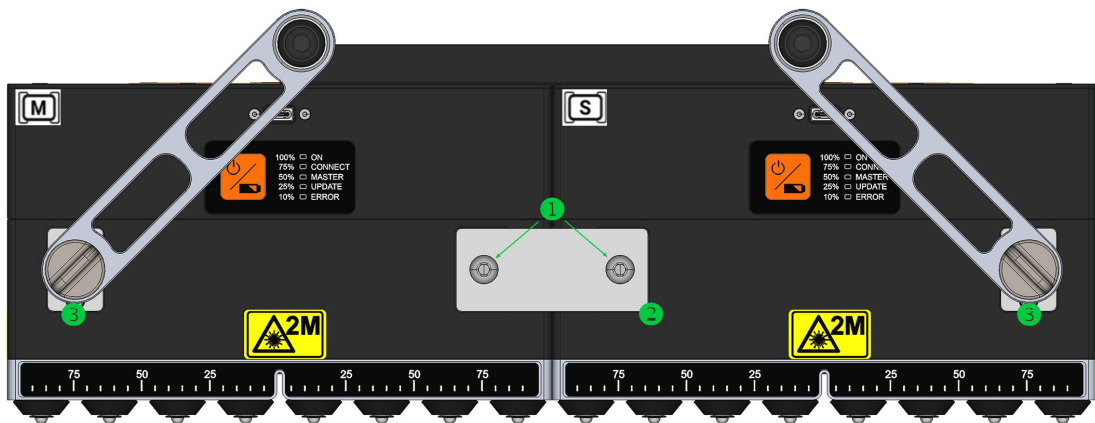

Figure 2: Assembly

- Dismount two h-fasteners **2**. Pus the screws and fasteners into the case pocket.
- Unscrew four handle bolts **3** on both sides of the tomograph
- Detach the handles from the secondary unit.
- Put the secondary unit in to the case
- Attach the handles to the primary unit



- Fasten the bolts **3** on

NOTE

Assemble the A1040 MIRA 3D PRO in the reverse order.



WARNING

Remove and mount the handles very carefully. Avoid deformation of the handle elements and housing damaging.

7 Main Components



Main device

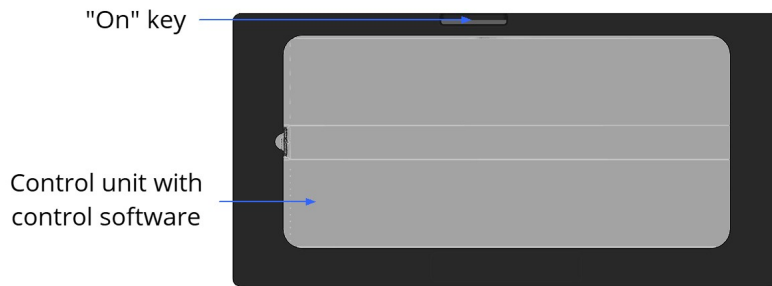

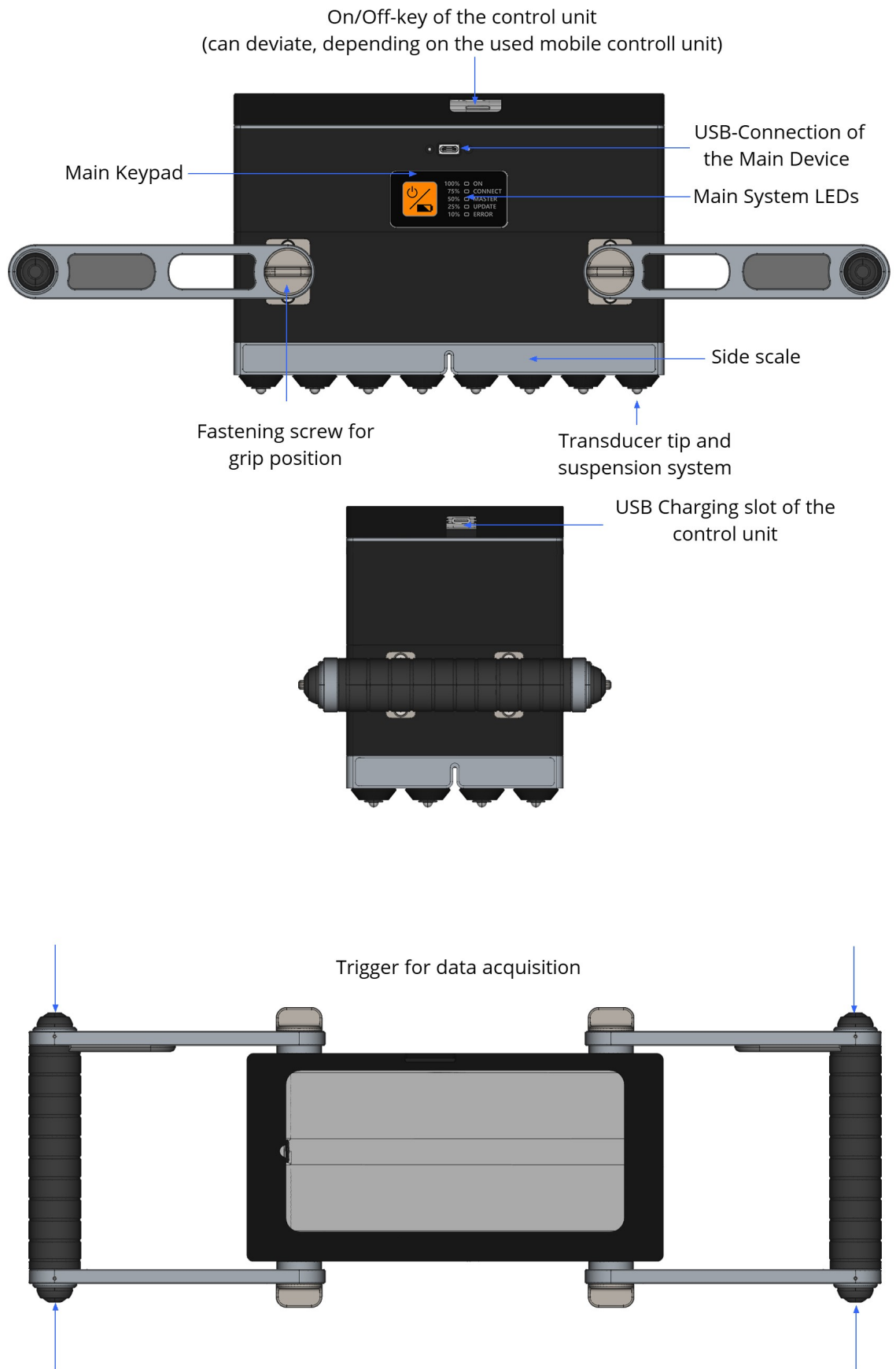

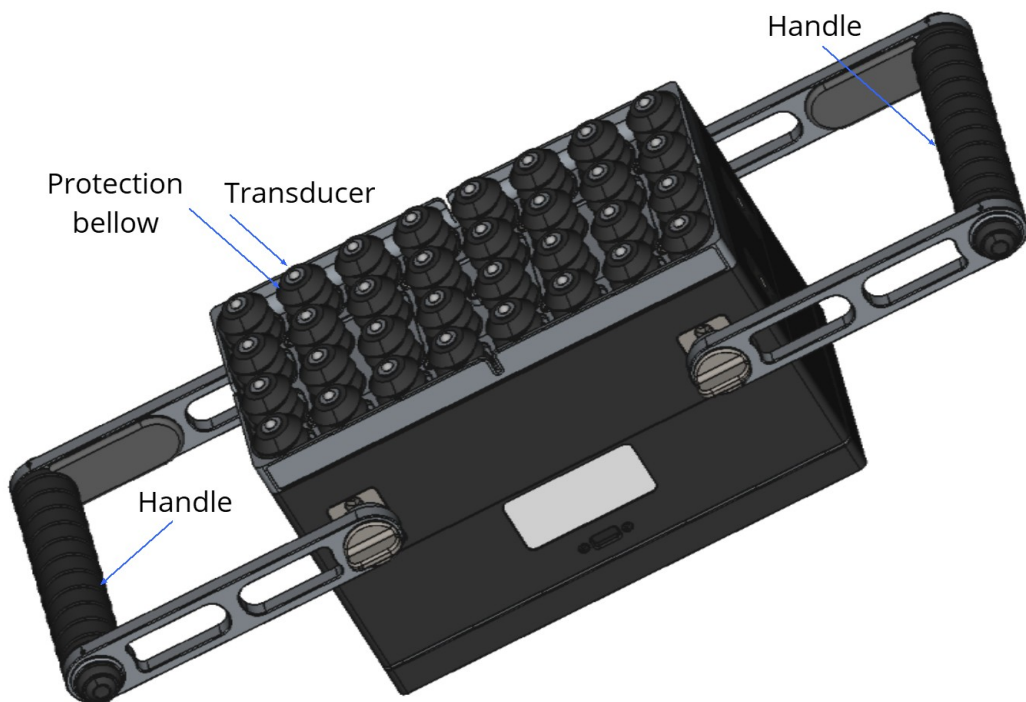
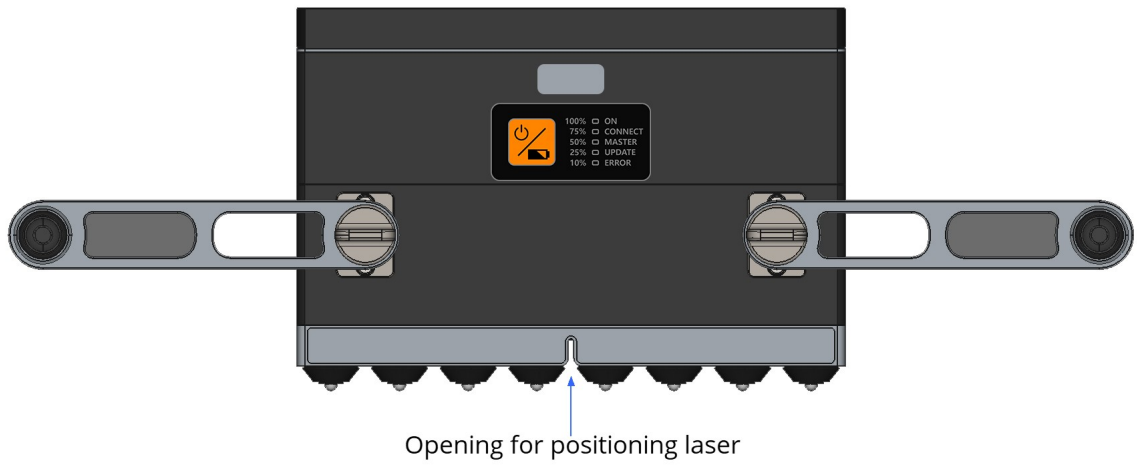

8 Keys and system LEDs

The A1040 Mira 3D Has two key -Types

Type One is the key for the operational preparation of the system and to run status checks. This KEY is found on the Main Keypad



Figure 3: Keypad position

The Keypad has three basic functionalities. Switching the device on/off and start the battery charging status. Detailed Information is given in the table below.

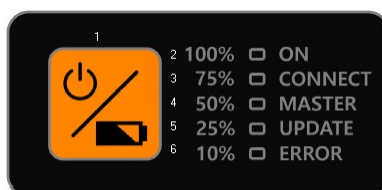
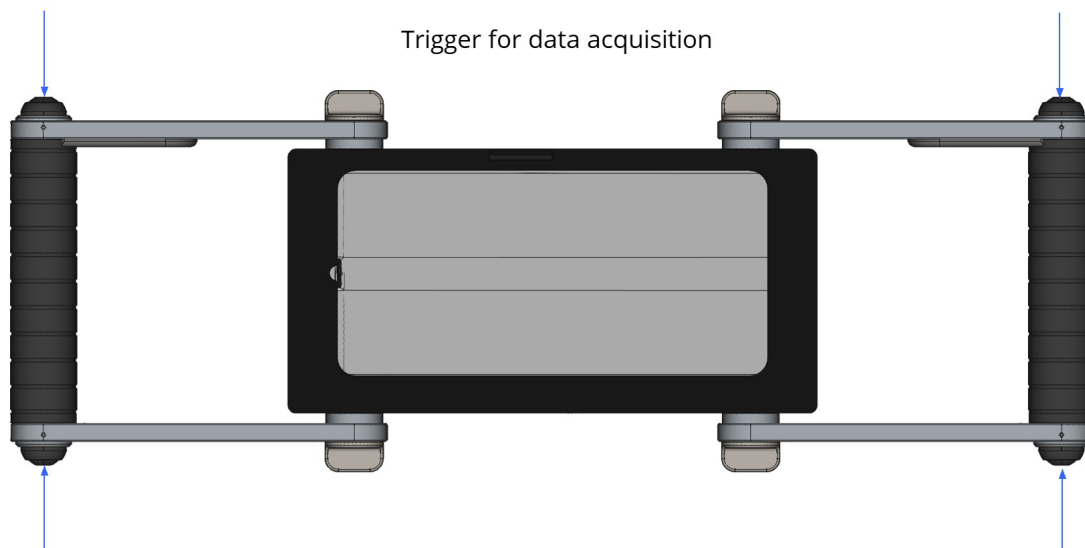

Figure 4: Keypad with LEDs

Key name	Functions
Power Key [1]	Press and hold the POWER Key for 3 seconds to activate the device
Power Key [1]	Press and release the POWER Key for the checking the battery status
Power Key [1]	Press and hold the POWER Key for 3 seconds to deactivate the device
Power Key [1]	Update procedure initiation (see chapter system update)

Type two is are the four trigger keys for the start of the acquisition during the system operation.



Key name	Functions
Trigger Key [2]	Data acquisition
Trigger Key [2]	Update initiation function when using WIFI as access point

The system LEDs have two basic functionalities, displaying the procedure mode and the charging status.

Normal operation mode

LED Name	Functions/Meaning
ON [2]	Not lit when device is turned off Flashing green during hardware initialization and booting Constant green glow when the device is ready for operation
CONNECT [3]	Not lit when device is turned off Flashing green with 1 Hz frequency until a connection is established with the access point of the control device. Flashing green with 2 Hz frequency until the connection with the control program is established. Constant green glow when the Main Device is connected to the control program and ready for operation

MASTER [4]	<p>Not lit:</p> <p>Option 1: The main device is not connected to the control program.</p> <p>Option 2: The main device is acting as slave in combination 4x16 or 8x8 with another device.</p> <p>Constant orange glow when the device is connected as Master to the control program.</p>
UPDATE [5]	<p>Not lit when device is in normal operation mode.</p> <p>Constant orange glow when the Main Device is connected to a PC and ready for receiving the update files. See chapter Update at page 99</p> <p>Flashing orange with 2 Hz frequency during the data transfer process.</p>
Error [6]	This LED has no functionality at the moment.

Checking the battery status mode. The LEDs are glowing constantly for a few seconds according the charging status and then switch off. The main device will stay switched off.

100 % [2]	green 100 % battery charging
75% [3]	green 75 % battery charging
50% [4]	orange 50 % battery charging
25% [5]	orange 25 % battery charging
10% [6]	red 10 % battery charging *
* at 10 % battery charging. the device should be recharged.	

9 Rechargeable Battery of the Main Device

**WARNING**

The rechargeable batteries of the Main Device shall not to be replaced by the operator, only by full trained personnel that has been authorized by ACS. For safety reasons, do not attempt to remove or replace the battery.

Incorrect removal or replacement of the battery may result in damage to the battery and the device, personal injury, and / or equipment damage including impairment of safety.

ACS is not liable for any damage or loss (whether contractually or unauthorized, including negligence) caused by not following this warning.

NOTE

Before first use, the rechargeable batteries must completely be charged.

If the instrument is not used for a period longer than three month, check charging status by press ON key short. When the charge has dropped to 25 %, recharge the device.

Make sure that the accumulator is completely charged once in two months, to prevent total discharge.

In that case of total discharge, the rechargeable batteries may be destroyed and must be replaced.

**WARNING**

Use only ACS - approved chargers and cables. Unauthorized chargers or cables may cause the batteries to explode or damage the device.

ACS is not liable for any damage or loss (whether contractually or unauthorized, including negligence) caused by not following this warning.



WARNING

Incorrect connection of the charger may cause serious damage to the device. Damage caused by improper use is not covered by the warranty.

Charging of the rechargeable battery

1. Connect one end of the USB-C cable to the USB-C power supply, and the other end to the USB-Connection of the Main Device



2. Connect the USB power supply to the mains socket.
3. When the charging process begins, the LED corresponding with the charging level will start to blink and glow constantly. When the status is reached the LED glows constantly and the LED for the next level will start to blink. .When the battery is charged 100 %, the 100 % LED is glowing constantly and the charging process is switching to trickle charge.

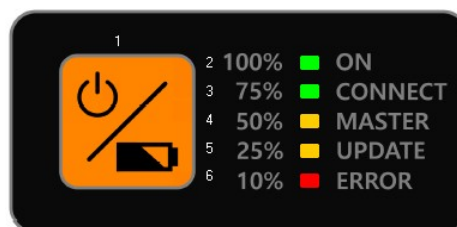

4. Separate the charging unit from the device, as the rechargeable battery has completely been charged.
5. First disconnect the charger from the device and then from the mains socket.

NOTETips and precautions for charging the battery

- In normal mode the device switches OFF as soon as the level drops beyond a certain safety limit. It is recommended not to restart the device before the charging procedure is complete to avoid damage.
- When the battery is discharged, the device will not turn on immediately after it has been connected to the charger. Charge the battery for a few minutes before turning the device back on.
- If the device is not charged through the USB power supply, but for example via a computer, this may result in a reduced charging speed due to a limited electrical power supply
- You cannot use the device while it is being charged.
- A moderate increase of temperature during charging procedure is not critical. In the case of a drastic temperature rise on the other hand, the charging unit must be removed at once.
- The charger does not have an on / off switch. So, you need to disconnect the charger from the power socket when not in use to prevent wasting energy.
- It is advisable to install the charging unit close to the mains connection and to keep the surroundings free, so that easy access is possible anytime.

10 Rechargeable Battery of the Control Unit

Rechargeable Battery of the Control Unit



CAUTION

A1040 Mira 3D is normally equipped with a tablet device as Control Unit that is seated in a specially developed housing. The Control Units provided by ACS are selected to guarantee a save and reliable operation of the all over system. The housing provides an opening for charging the control unit via the USB-C.

Please do not try to open the provided housing for the control unit. If the control Unit is damaged or malfunctioning, please contact your ACS support.

**WARNING**

Do not try to control the A1040 Mira 3D with other mobile devices that are not specified and provided by ACS, even if the connectivity and capability of executing the control software is given. This may result in unexpected behavior, personal injury, and / or equipment damage including impairment of safety. ACS is not liable for any damage or loss (whether contractually or unauthorized, including negligence) caused by not following this warning.

**WARNING**

Use only ACS - approved chargers and cables. Unauthorized chargers or cables may cause the batteries to explode or damage the device.

ACS is not liable for any damage or loss (whether contractually or unauthorized, including negligence) caused by not following this warning.

**WARNING**

Incorrect connection of the charger may cause serious damage to the device. Damage caused by improper use is not covered by the warranty.

Charging of the Control Unit

1. Connect one end of the USB-C cable to the USB-C power supply, and the other end to the USB-Connection of the Control Unit

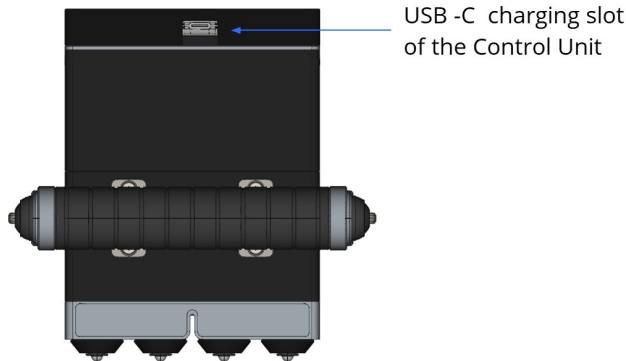

2. Connect the USB power supply to the mains socket.
3. When the charging process begins, the display of the Control Unit states, that the device is charging. When the device is fully charged, the percentage value next to the battery symbol shows 100 %. When the battery is charged 100 %, the charging process is switching to trickle charge.
4. Separate the charging unit from the device, as the rechargeable battery has completely been charged.
5. First disconnect the charger from the device and then from the mains socket.



WARNING

Charge mobile control only with dedicated cable. For more information refer [page 12](#).

NOTE

Tips and precautions for charging the battery

- In normal mode the device switches OFF as soon as the level drops beyond a certain safety limit. It is recommended not to restart the device before the charging procedure is complete to avoid damage.
- When the battery is discharged, the device will not turn on immediately after it has been connected to the charger. Charge the battery for a few minutes before turning the device back on.

- If the device is not charged through the USB power supply, but for example via a computer, this may result in a reduced charging speed due to a limited electrical power supply
- You cannot use the device while it is being charged.
- A moderate increase of temperature during charging procedure is not critical. In the case of a drastic temperature rise on the other hand, the charging unit must be removed at once.
- The charger does not have an on / off switch. So, you need to disconnect the charger from the power socket when not in use to prevent wasting energy.
- It is advisable to install the charging unit close to the mains connection and to keep the surroundings free, so that easy access is possible anytime.

11 Device usage and Limitations

**WARNING**

This section contains safety-relevant information and defines minimum requirements for user groups. Use of the device outside the intended use and by unintended user groups may result in damage.

Intended use

The A1040 MIRA3D device is intended for the ultrasonic inspection of constructions made of concrete, reinforced concrete and stone with one-sided access.

The design is for manual operation on controlled environment and on surfaces prepared for the ultrasonic testing. Only even surfaces, free from interfering material like dust and sand or other loose particles will provide reliable results.

Never use the device on Surfaces with high dust, sand or other particle load. ACS is not liable for any damage or loss (whether contractually or unauthorized, including negligence) caused by not following this warning.

**WARNING**

The A1040 shall only be used in controlled areas with no explosive atmosphere.

User groups

Group	Minimum Age	Qualification	Task
Qualified Operator	18 years	Trained in handling of measurement equipment, trained in work safety for the corresponding area	Ultrasonic inspection of constructions made of concrete, reinforced concrete and stone with one-sided access
Apprentices/ Trainees/ Students:	16 years	Trained in handling of measurement equipment, trained in work safety for the corresponding area	Ultrasonic inspection of constructions made of concrete, reinforced concrete and stone with one-sided access under supervision.
Public (e.g. visitors)	No user group. The handling of the measuring device is prohibited for these persons.		
Vulnerable persons (e.g. pregnant women)	No user group. The handling of the measuring device is prohibited for these persons.		

Ambient limits

- Temperature Range:
 - Storage: From -20 °C to +60 °C
 - Operation: From -10°C to +50°C
- Relative humidity: 95%
- Contamination: Despite the provided protection according to IP 53 (dust, splash water) always minimize the contact of the device with particles and fluids.



WARNING

Never use the device on Surfaces with high dust, sand or other particle load. ACS is not liable for any damage or loss (whether contractually or unauthorized, including negligence) caused by not following this warning.

- After use, the device must be cleaned and stored in the transport box provided for this purpose.

Reasonably foreseeable misuse



CAUTION

The device may only be operated by trained personnel. Nevertheless, misuse is not excluded if care is not taken. For troubleshooting, see "Troubleshooting"

Problem cause	Consequence
Incorrect use of the test block	Incorrect measurement
Skewed or improper placement of the device on the testing surface	Incorrect measurement
Insufficient grip of the device, unsafe testing positions, dropping the device	Damage of casing, rechargeable battery, display, electronics. Loss of IP protection.
Insufficient attachment of the handle arm/ open fastening screws for grip adjustment	Dropping of the device and injury by uncontrolled movement of the device.

12 Safety

**WARNING**

The general safety instructions listed in this section are relate to the use of the device on workshops and constructions sites under controlled conditions.

These general safety instructions are no replacement for a risk assessment of the workplace according to BetrSichV §3, GefStoffV §6 and ArbSchG §5 and applicable additional national and international requirements by a health and safety officer or a specialist for occupational safety of the employer.

General safety instructions:

- The equipment should not be handed over to persons not aware of inherent risks of the device use or not knowing the content of this manual.
- Be sure to stand securely when measuring with the device.
- Keep a good posture during the handling of the device and avoid movements that will overloading your joints, ligaments and muscles.
- Pay attention to your environment and potential hazards during the measurement.
- Always mechanically secure the device from falling when used in elevated positions or areas.

**WARNING**

The Device contains four Class 2M laser for positioning purposes. The Laser are located at the bottom of the device.

Specific safety instructions:

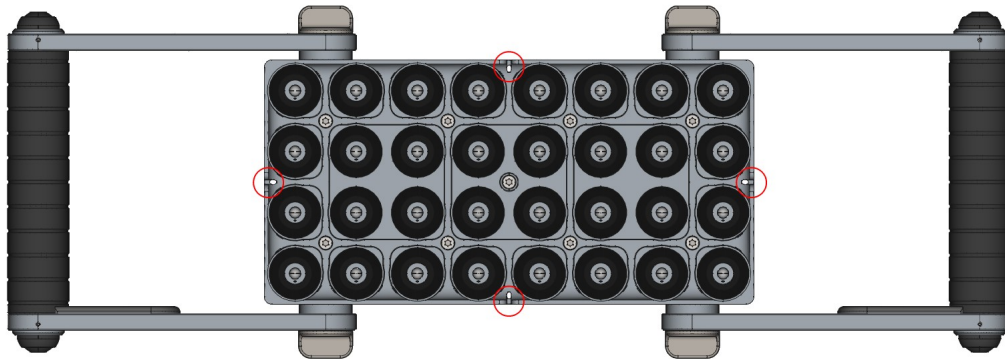

All laser outlets are marked with the following symbol

Protective measures:

- Work with laser systems may only be carried out by trained and qualified persons.
- Avoid looking directly into the laser beam (direct or reflected beam).
- If the lasers are not needed, switch the lasers off.
- If you do not work directly with the laser, keep your distance to the equipment.
- Laser radiation, may only extend as far as necessary for the task at hand.
- Do not wear watches and jewelry during the use of the lasers to avoid accidental reflections.
- The beam cross section must not be reduced.
- Laser equipment shall be installed or secured in such a way as to avoid any unintentional change in its position and beam direction, including those located in the beam path.
- A minimization requirement applies both with regard to the spatial size of the laser area and the number of people staying in the laser area.
- Keep laser under lock to prevent misuse.

13 Maintenance and Repair

NOTE

For this measuring device, calibration is imperative. It should be included in the measuring equipment monitoring of the enterprise.



CAUTION

Always keep the A1040 Mira 3D clean and maintained state. Avoid unnecessary force when using the device and always dry and clean the device before storage. For storage use the provided box with the foam inlay. Also clean and dry the insides of the box before the device is stored inside. See chapter Troubleshooting for first steps if you are in need of help or find any malfunctions.

Preventive Maintenance

Frequency	Parts Concerned		Action
Before each use	Main Device:	Housing	Check for mechanical damage.
		Transducer mechanics	Check for smooth operation, mechanical damage and cleanliness
			NOTE
			Never try to remove the protection bellow . Never try to lubricate the the suspension system.
		Transducer tips	Check for mechanical damage and cleanliness
		Protection bellows	Check for mechanical damage and cleanliness
Information Sticker	Check for completeness and readability.		

		USB-C socket	Check for mechanical damage and cleanliness.
	Control Unit		Check for mechanical damage and cleanliness.
Before functionality check	Transducer test plate		Check for mechanical damage and cleanliness.
After each use	Main Device:	Housing	Check for mechanical damage.
		Transducer mechanics	Check for smooth operation, mechanical damage and cleanliness
			NOTE
			Never try to remove the protection bellows . Never try to lubricate the the suspension system.
		Transducer tips	Check for mechanical damage and cleanliness / Clean the transducer tips with a small, soft brush and a little moistened cloth.
	Protection bellows	Check for mechanical damage and cleanliness / clean the Protection Bellows with a small, soft brush and a little moistened cloth.	
		Information Sticker	Check for completeness and readability / Clean with a little moistened cloth / Ask service for replacement of missing or unreadable stickers.
	Control Unit		Check for mechanical damage and cleanliness / Clean with a little moistened cloth
Once per year	Complete A1040 Mira 3D system		Inspection and calibration by ACS or authorized dealer.

Control procedures and test equipment

Correct functionality is inspected by means of the test plate contained in the set. The procedure is detailed at [page 79](#).

Documentation of Maintenance

The annual inspections must be documented by factory service or the authorized person for measuring equipment monitoring.

Repair

Repair is reserved to factory service or authorized dealer.

Initial Step for Troubleshooting

In case of device failure switch OFF and ON the device. If the device problem is not solved, consult the chapter troubleshooting.

14 Technical Specification

NOTE

The technical specification is given in the A1040 Mira 3d warranty certificate, chapter 3 "Main Technical Specifications", that was given to you as part of the delivery set.

NOTE

The technical specification can be altered by ACS anytime by means of optimizing the device or for safety reasons. Please check the homepage path of [A1040 MIRA 3D](#), for the latest technical specification of the device.

15 Operation

NOTE

The given operation description of this chapter relates only to achieve a status of operation readiness. All parameters available for setting to meet the develop a testing procedure and to perform tests are described in the chapters x,y,z,

Set up of the Grip position

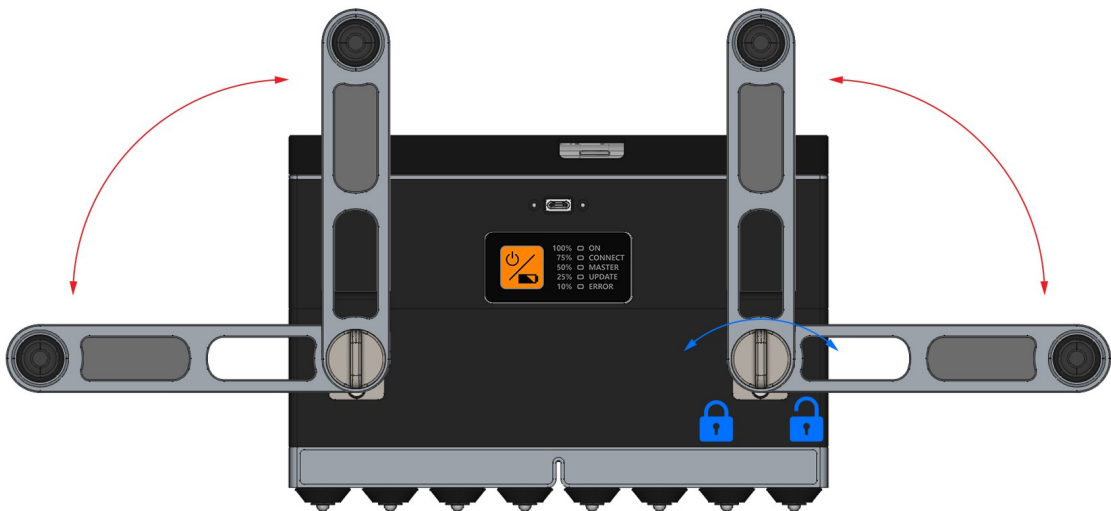

NOTE

The handle screws are designed to be operated by hand only. For the operation of the screws only little force is needed for secure fastening results. Never use tools on the handle screws !



Unlock the handle fastening screws on both sides of the handle by rotating them counter clockwise.

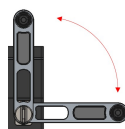

Move the Handle into one of the four possible positions.



Lock the handle fastening screws on both sides of the handle by rotating them clockwise

Repeat the operation on the other handle.

Attachment and detachment of the control device

Place the Control Unit on the Main Unit like shown in the sketch below, gripping it on the corners.

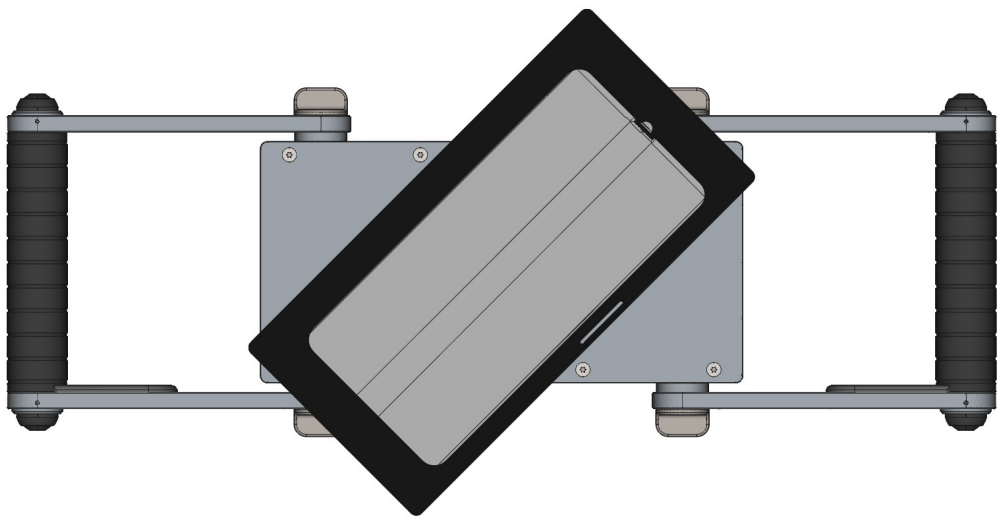

Rotate the Control Unit, gripping it on the corners, clockwise until the magnetic locking system snap into place.

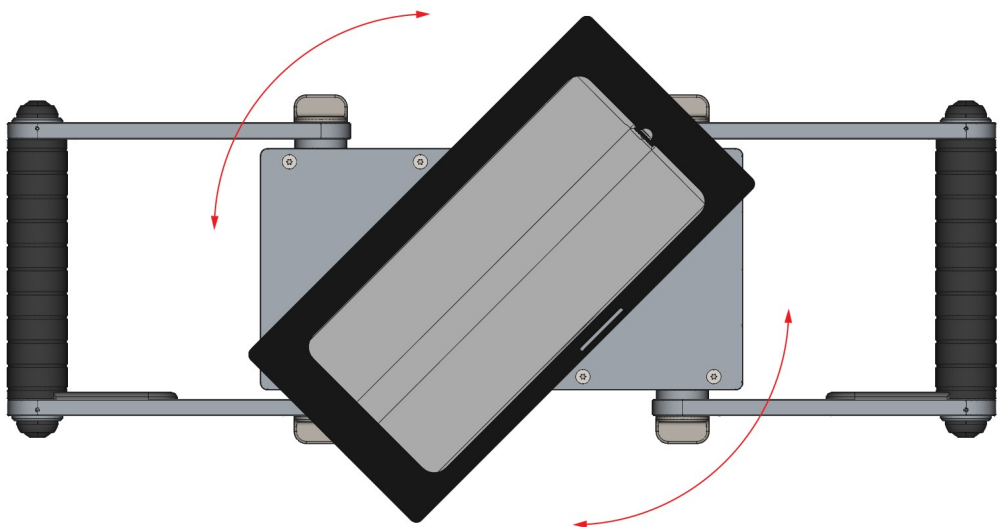

Correctly placed Control unit

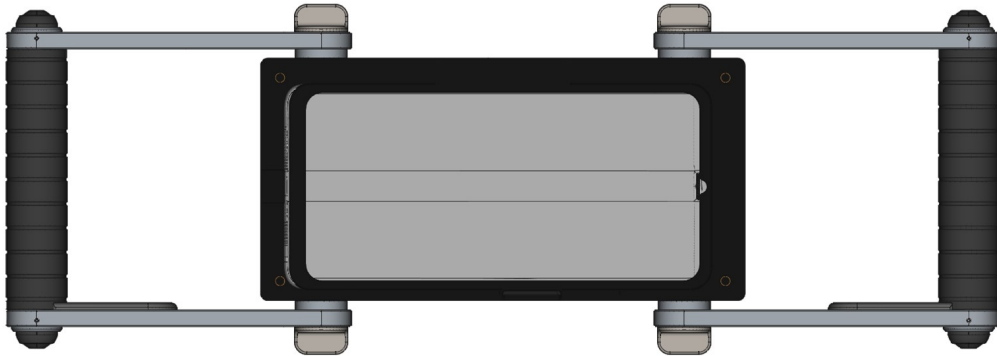

For detachment repeat the procedure backward.

Rotate the Control Unit, gripping it on the corners, until the magnetic locking system snap out of place .

Remove the Control Unit from the Main Unit.

Switching on the A1040 Mira 3D system

NOTE

Before switching on the A1040 Mira 3D system, check the status of the batteries according the chapters "Rechargeable Battery of the Main Device" and "Rechargeable Battery of the Control Unit"

Press On Key [1] for three seconds to switch the Main device on.

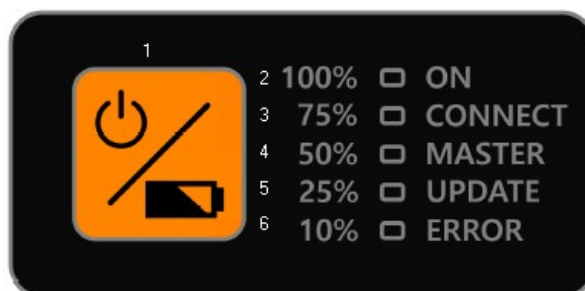

Switch on the Control Unit by pressing the On Key, shown in the figure below

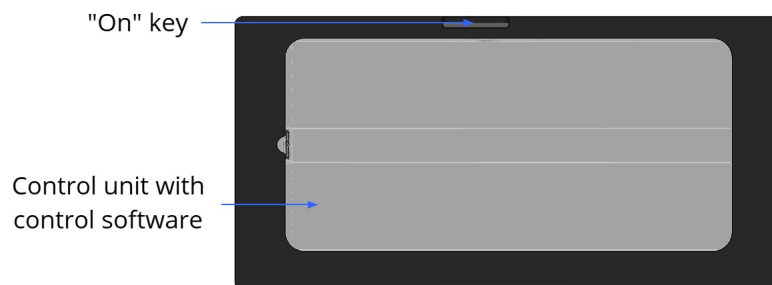

Switching off the A1040 Mira 3D system

Press On Key [1] for three seconds to switch the Main device off.

Switch off the Control Unit by pressing the On Key

16 Trouble shooting

Problem	Possible Reason(s)	Action
<p>Main Device does not switch on.</p> <p>The ON LED is not flashing green after pressing the ON key for three seconds.</p>	<p>Rechargeable Battery not charged</p>	<p>Press the ON Key short to check the Battery charging status. If the status is low (e.g. the red LED that equals 10 % is blinking) charge the batteries.</p>
	<p>The Main Device has a malfunction that can only be determined by trained service personnel</p>	<p>Send the device back for repair in its original box, or hand it over to a designated collection point for recycling.</p> <div style="border: 1px solid black; padding: 5px; text-align: center;">NOTE</div> <p>The product must not be disposed of with the domestic waste.</p>
<p>Main Device does not initialize the hardware and boot the firmware.</p> <p>The ON LED is flashing green after pressing the ON key for three seconds but is not constantly glowing after some time.</p>	<p>The software of the Main Device is malfunctioning or was damaged.</p>	<p>Switch off the Main Device by pressing the ON key for three seconds.</p> <p>Switch on the Main Device by pressing the ON key for three seconds.</p> <p>Try to perform a firmware update according chapter Update⁹⁹.</p>
	<p>The Main Device has a malfunction that can only be determined by trained service personnel</p>	<p>Send the device back for repair in its original box, or hand it over to a designated collection point for recycling.</p> <div style="border: 1px solid black; padding: 5px; text-align: center;">NOTE</div> <p>The product must not be disposed of with the domestic waste</p>
<p>Main device is not detected by mobile unit.</p>		
<p>Laser does not work or is blurred</p>	<p>Dirt or or a small item is blocking the laser beam outlet.</p>	<p>Switch off the laser LEDs by the control software.</p>

		<p>Check if the LEDs are off by placing the device on white A4 sheet of paper, or similar. .</p> <p>When the LEDs are off, turn the deice to the and clean the laser beam outlet with a small blower ball, soft brush or peace of cloth.</p> <p>Check the outlet and the lens for cleanliness.</p> <p>Check the function by placing the device on on white A4 sheet of paper, or similar and switch the laser LEDs on by the control software.</p>
		<p> WARNING</p> <p>Never look directly in the laser beam and make sure, that the laser beam is never directed to the eyes of any bystander. Also avoid mirroring surfaces like glass, liquids or polished metal objects.</p>
	<p>The LED is damaged</p>	<p>Send the device back for repair in its original box, or hand it over to a designated collection point for recycling.</p> <p>NOTE</p> <p>The product must not be disposed of with the domestic waste</p>
<p>Transducer is stuck / suspension is not working</p>	<p>Dirt intrusion due to damaged or loosened protection bellow.</p>	<p>Check the protection bellow for damage and if it is disassembled. A well assembled an intact bellow is shown in the sketch below.</p>

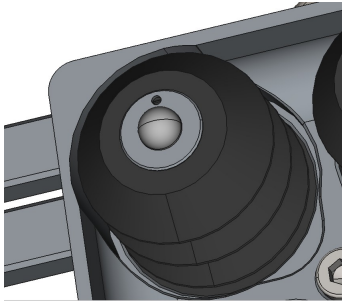
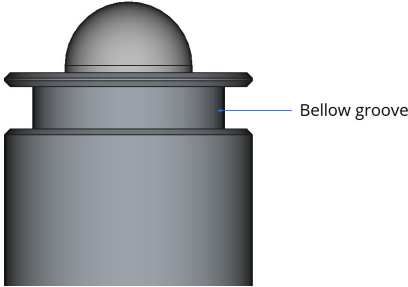
		 <p>If the bellow is disassembled, carefully try to retract the bellow until the sensor suspension is visible. Try to clean the suspension with a small brush and a little moistened cloth.</p> <p>Check if the suspension is working now.</p>
<p style="text-align: center;">NOTE</p> <p>Never try to remove the protection bellow .</p>		<p>Place the bellow back and make sure the end of the bellow rests now in the designated groove.</p>
<p>Never try to lubricate the the suspension system.</p>		 <p>If the bellow is damaged, it must be replaced by a service technician.</p>
	<p>Spring malfunction/damage or damage at the mechanical transducer guiding system.</p>	<p>Send the device back for repair in its original box, or hand it over to a designated collection point for recycling.</p> <p style="text-align: center;">NOTE</p> <p>The product must not be disposed of with the domestic waste</p>
<p>Main device is not detected by the Mobile Unit</p>	<p>Malfunction during the coupling process</p>	<p>Check if the On LED on the Main Device is glowing green constantly.</p> <p>Switch off the Mobile Unit.</p> <p>Switch on the Mobile Unit</p>

		Go to chapter at page 98 and follow the instructions for the device coupling process.
	Software malfunction	Check if your Control Software on the Mobile Unit is starting properly. If the software is not responding properly, reinstall the software on your Mobile Unit.
Plattentest fail		
Main Device does not switch off after pressing the ON key for three seconds.	The control software is malfunctioning.	Disconnect the Mobile Unit form the Main Device. Disconnect all cables from the Main Device. Retry switching off by pressing the ON Key for three seconds
	The Main Device has a malfunction that can only be determined by trained service personnel	Let the Main Device switched on, until the batteries are discharged enough and no LEDs is lit any more. Send the device back for repair in its original box, or hand it over to a designated collection point for recycling.
		NOTE
		The product must not be disposed of with the domestic waste.

17 CE Certificate



Declaration of Conformity according to EMC Directive 2014/30/EU

The manufacturer / distributor

ACS-Solutions GMBH, Science Park 2, 66123 Saarbrücken Germany

hereby declares that the following product

Product name: Low-Frequency Ultrasonic Tomograph
Trade name: Ultrasonic measuring device
Model name: A1040 MIRA 3D

complies with the provisions of EMC Directive 2014/30/EU, including any changes in force at the time of the declaration.

The following harmonized standards have been applied:

EN 55011:2016	Industrial, scientific, and medical devices - Radio interference - Limit values and measurement methods
EN 61000-6-2:2015	Electromagnetic Compatibility (EMC) - Part 6-2: Basic Technical Standards - Immunity for Industrial Sectors
EN 61000-4-2:2009	Electromagnetic Compatibility (EMC) - Part 4-2: Test and measurement methods - Testing of immunity against the discharge of static electricity
EN 61000-4-3:2006+ A1:2008+A2:2010:	Electromagnetic Compatibility (EMC) - Part 4-3: Test and measurement methods - Immunity testing against radiofrequency electromagnetic fields

The test results were documented in EMC Test Report 83418_24112020_A1040 MIRA 3D from 30/11/2020 by SGS TÜV.

The following national or international standards (or parts/clauses thereof) and specifications have been applied:

EN 61010-1 Safety requirements for electrical equipment for measurement, control, and laboratory use - Part 1: General requirements

Procedures for carrying out risk analysis

Directive 2014/30/EU, Annex I, point 1 and Annex II Module A

Risk assessment procedures

DIN ISO/TR 14121-2 Safety of machines - Risk assessment - Part 2: Practical guide and process examples, 6.3 Risk graph

Location: Saarbrücken

Date: 11.12.2020

Dr. Andrey Bulavinov (Managing Director)



18 B-Scan

B-Scan serves for fast random measurements along the object. These measurements are considered to be spatially independent. In a short period of time, the operator can optimize measurement parameters taking into consideration different areas of the object. Measurement of the object thickness as well as sound velocity can be also done on the fly. Moreover, examination of suspicious areas, location of reinforcement, etc. is also offered.

18.1 Information panel

The B-Scan information panel **1**, Figure 5 shows the following parameters:

Parameter	Description
2	Amplitude indicator. This shows the amplitude at the cross-cursor position or the found maximum (depends on the selected <code>Cursor</code> parameter, for more information refer to the chapter ^[50]). The amplitude units are dB. The amplitude indicator also informs about possible overflow. For more details refer to the chapter on the page ^[117] .
3	X-coordinate indicator. Shows the X-coordinate of the the cross-cursor position or the found maximum (depends on the selected <code>Cursor</code> parameter, for more information refer to the chapter ^[50]).
4	Z-coordinate indicator. Shows the Y-coordinate of the the cross-cursor position or the found maximum (depends on the selected <code>Cursor</code> parameter, for more information refer to the chapter ^[50]).
5	Analog gain indicator. Shows the actual <code>Analog gain</code> , for more information refer to the chapter ^[48] .
6	Digital gain indicator. Shows the actual <code>Digital gain</code> , for more information refer to the chapter ^[48] .
7	Velocity indicator. Shows either estimated or user defined sound velocity.

18.2 Main parameters

Main parameters tab of B-Scan mode **7** mostly contains parameters affecting ultrasonic characteristics of measured signals (Figure 5). Operator can scroll the list of parameters up and down.

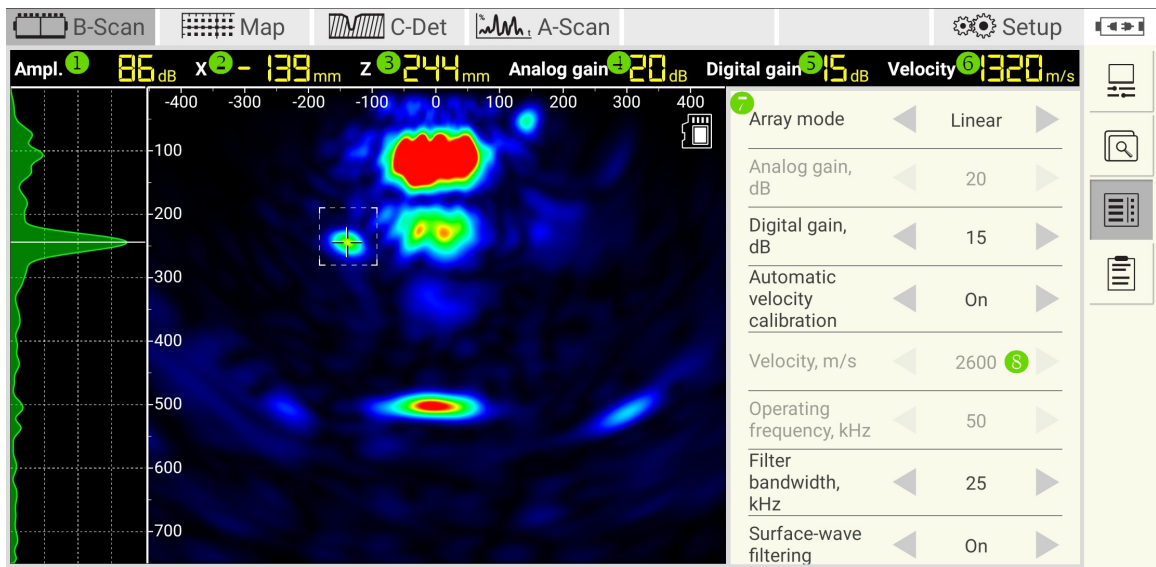

Figure 5: B-Scan main parameters

Table 1: Description of parameters

Parameter	Description
Array mode	Switches between linear or matrix device mode.
Analog gain, dB	For detailed description refer to the chapter^[117] .
Digital gain, dB	This parameter can be used to increase the digital signal after it has passed the A/D-conversion. Digital gain is expressed in db. Digital gain does not improve digital resolution rather equally amplifies both signal and noise. The parameter allows to improve contrast of resulting images.
Automatic velocity calibration	The operator can switch on or switch off the automatic velocity estimation. If the parameter is off, the operator may set the velocity in the field 8 manually. If the parameter is on, the app estimates velocity based on the measured data.
Velocity	Sets the user defined sound velocity
Operation frequency, KHz	Sets frequency of excitation pulse on ultrasonic transducers. Default frequency is 50KHz-
Filter bandwidth, KHz	Digital filter bandwidth with central frequency equal to operation frequency.
Show TGC	Option to show/hide TGC curve on an A-Scan.
TGC, dB/μs	Time gain compensation (TGC) parameters , see detailed description on the page^[118]
TGC delay, μs	
Transmitter pulse sequence	Defines number of half-periods of excitation pulse, for reference see page^[122]
S-TGC	Software time gain correction parameters, see detailed description on the page^[120]
S-TGC delay, μs	
E-Boosting	Parameter of the E-Boosting feature, for reference see page^[125]

18.3 Display parameters

Display parameters allows user to adjust representation of inspection results in a best suitable way. Main screen of display parameter tab and corresponding description are given below.

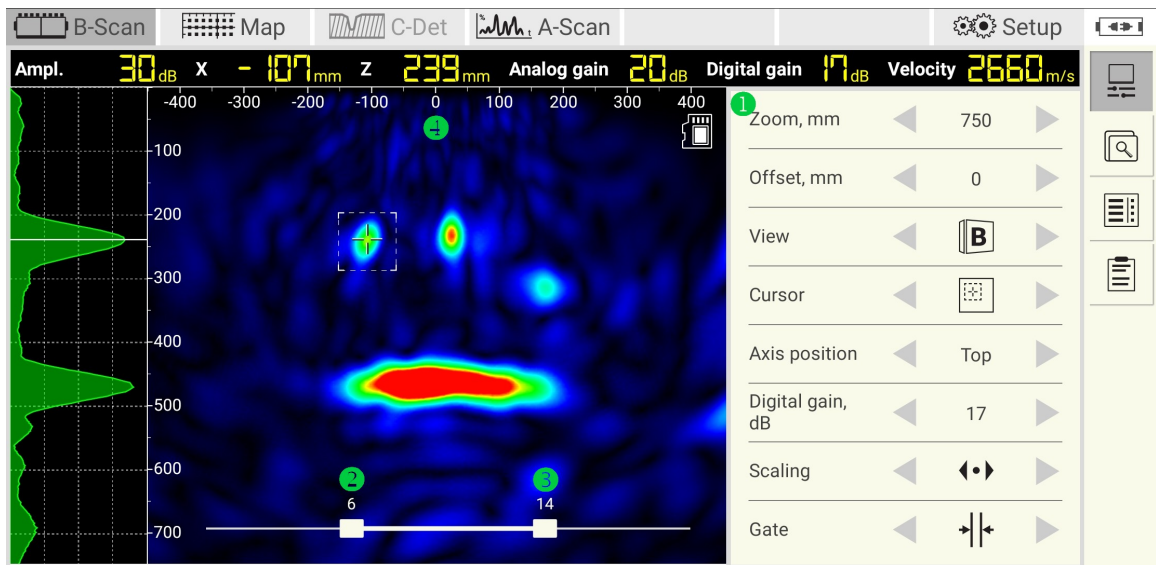









Table 2: Description of controls

Lable	Description
①	Tab with listed display parameters
②	Start gate control. Defines first cross-section to be projected. Available in matrix array mode.
③	End gate control. Defines last cross-section to be projected. Available in matrix array mode.

Table 3: Description of parameters

Lable	Icon	Description
Zoom	-	Parameter specifies limit of B-Scan inspection depth. Available in liner array and matrix array mode.
Offset	-	
View		Data are shown as a flat B-Scan (front view) image. In matrix array mode the operator can setup desired projection depth by means of Gate control.
		Data are shown as 3D volume. Available in linear and matrix array mode
		Data are shown as flat C-Scan (top view) image. In matrix array mode operator can setup desired projection depth by using of Gate control.
Cursor		Type of cursor offers for the operator automatic search of a maximal amplitude inside the cursor area. The position of the maximal amplitude is pointed by cross-lines. A-scan waveform corresponds to the horizontal position of the cross-lines.

		Type of cursor offers operator to manually specify position of cross-lines over b-scan. Horizontal and vertical lines are hidden in order to avoid obstruction of information shown on b-scan.
		Classical type of cursor with elongated vertical and horizontal cross-lines.
Axis position	-	Allows changing the location of the x-axis  on the B-Scan. Three options are available: top, bottom or hide. Change the x-axis location if it obstructs the view to an indication on the B-Scan
Digital gain	-	Refer to page  48
Scaling		Depth and width relations of B-Scan or C-Scan are proportional. The operation can scroll an image both left and right using touch.
		B-Scan or C-Scan are fitted to screen. Depth and width proportions are not preserved.
Gate		Allows the operator to examine data using cross-sections
		Operator can setup a number of cross-sections which will result into a single image.

18.4 File manager

The file manager  provides saving, loading, deleting, sharing, renaming and creating of measurements.

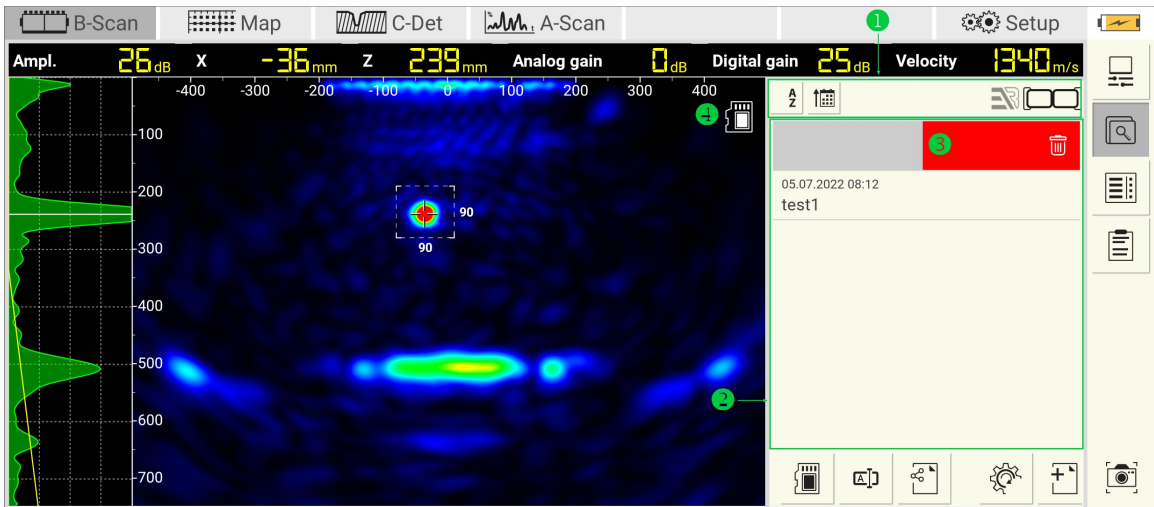

Figure 6: File manager

Mode

The file manager causes the app to switch between the online and offline modes. In the online mode, the app receives data from the tomograph. In the offline mode, the app operates with some saved data.





NOTE

The online mode is only available if the tomograph is online. For more information refer to [page 72](#).



Information panel

The information panel **1** has the following indicators:

Indicator	Icon	Description
Sorting by name	↓ A Z	indicates the measurements are sorted by name in the ascending order from A to Z
	↑ A Z	Switch (by tapping) to sort the list by name in the descending order from Z to A. Switch to it by tapping on the indicator.
	A Z	indicates that sorting by name is disabled
Sorting by date	↓ [Calendar]	indicates the measurements are sorted by date (date of creation or date of last editing) in the ascending order
	↑ [Calendar]	Switch (by tapping) to show the latest measurements first.

		indicates that sorting by date is disabled
E-Boosting		indicates the current license supports the E-Boosting feature, all E-Boosting features are available. For more information refer to the page¹²⁵ .
		indicates the current license does not support E-Boosting, all E-Boosting features are unavailable.
Measurement type		The list shows only 4x8 measurements.
		The list shows only 4x16 measurements. To change the configuration type refer to the page⁷² .

File manager panel

The `file manager` has a panel with the list of measurements **2** (Figure 6). Each item in the list has a name and the date and time when it was saved or changed. The list can be scrolled by touching with a finger and simultaneously moving up or down. Short tip on the list element causes the selection of this measurement followed by loading of its data. The app switches to the `offline` mode. The icon  **4** indicates whether the loading finished successfully. Tipping of the selected item switches the app to the `online` mode. There is no  indicator.

The list allows deleting an item by holding with a simultaneous horizontal right to left movement **3**.

Saving

Press the  button to save the current data and parameters. After pressing the button the keyboard **1** appears (Figure 7). Edit the name using the keyboard.

Confirm the changes with .



Figure 7: Saving dialog keyboard

Press the button 2 to show the list of the existing measurements 3. Select the name you want and press 4 to finalize your choice.

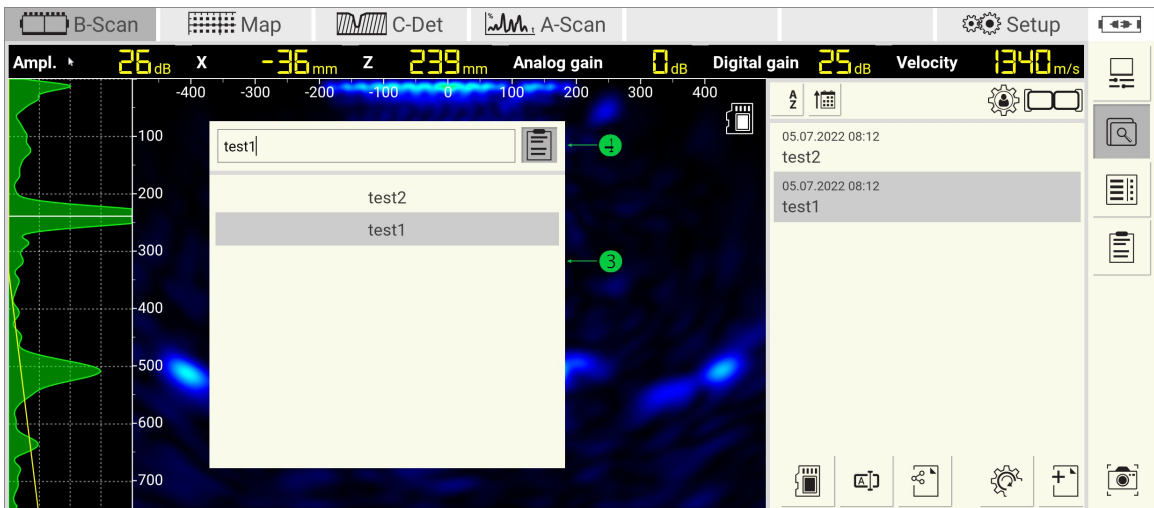

If necessary, adjust the name in the field 1 and press enter ↵ for saving.



CAUTION

Save any changes made on offline data. Otherwise, the changes will be lost.

Renaming

Press  to rename the measurement. After pressing the dialog similar to Figure 7 appears. Change the name and confirm the renaming with ↵.

Sharing

Press  to share the current measurement. After pressing the icon, the android operation system offers to choose a third-party sharing software. It can be an email client, a cloud app or any messenger. Install the sharing software before using this option.

NOTE

The app shares only *offline* data. Save the online measurement before sharing.

Default reset

Press  to create an *online* measurement with the default parameters.

NOTE

The defaults are the parameters recommended by the manufacturer. It is recommended to use the defaults when you start using the application.

New measurements

Press  to create a new online measurement with the parameters copied from the current measurement.

NOTE

To create an online copy of the offline measurement, load it first. After loading

press .

19 MAP

MAP mode allows the operator to carry out areal scanning of inspected objects. The operator is given a great variety of function to setup: area of interest, its dimensions, step size, scanning direction etc. Apart from this setting, the software has a number of integrated visualization features, data representation modes and analysis tools. Operator of can observe results of scanning even in real time while progressing with data collection. Description of functions, parameters and settings is given in the following chapters.

19.1 Information panel

Information panel in MAP mode are the same as in B-Scan mode. For more information refer to the [chapter 48](#).



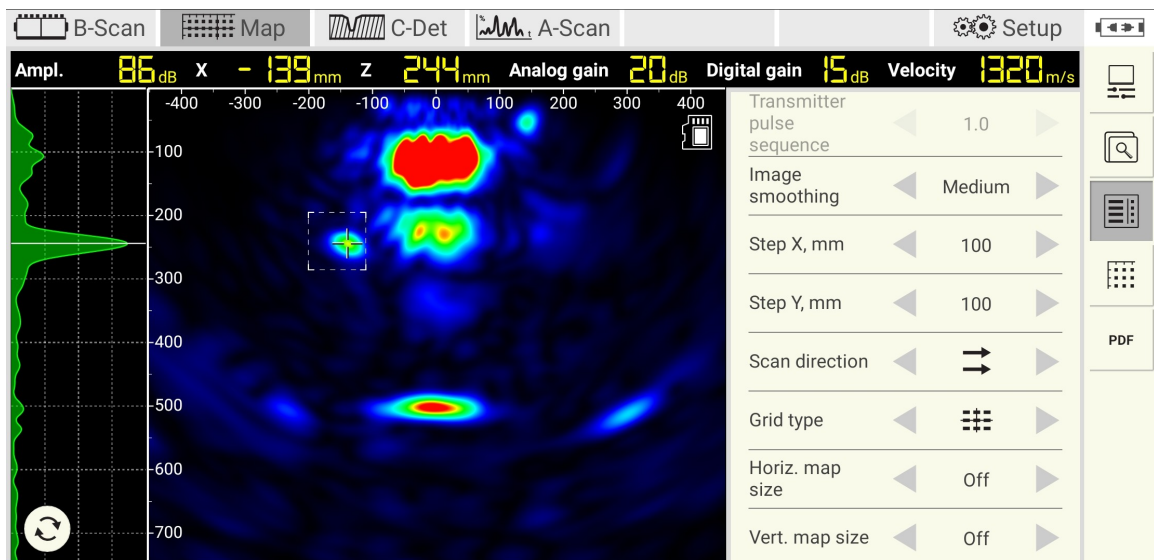

19.2 Main parameters

Main parameters of MAP mode are listed in corresponding tab as it shown below.



In MAP mode in comparison to B-Scan mode the list of main parameters has been extended. For description of standard parameters refer [to 48](#). Additional MAP parameters are listed in table below.

Table 4: Description of parameters

Lable	Icon	Description
Step X		Defines distance between measurement positions along X axis
Step Y		Defines distance between measurement positions along Y axis
Scan direction		Defines next measurement position with respect to the current one. Left, right, up and down options are available.
Grid type		Allows operator to load data from the selected measurement position.
		Allows operator to project all data to a single (panorama) image from the selected row. Merging is carrying out in accordance with xy coordinate.
		Allows operator to project all data into a single (panorama) image from the selected column. Projection is carrying out in accordance with XY coordinate.
		Allows operator to project all data from the selected area into a single (panorama) image.
Horiz. map size		Defines the limit of measurement positions along X axis . After reaching the last position operator will be offered to start a new horizontal line. Operator may switch off the limits.
Vert.map size		Defines the limit of measurement positions Y axis. Behaves similar to Horiz. map size

19.3 Display parameters

Display parameters in MAP mode are the same as in B-Scan mode. Please, refer to the list of display parameters [here](#)^[50].

19.4 File manager

File manager in MAP mode has similar functionality as the manager in B-Scan mode. Please, refer to file manager description [here](#).^[52]

19.5 MAP manager

MAP manager parameters are listed in the corresponding tab as is shown below.

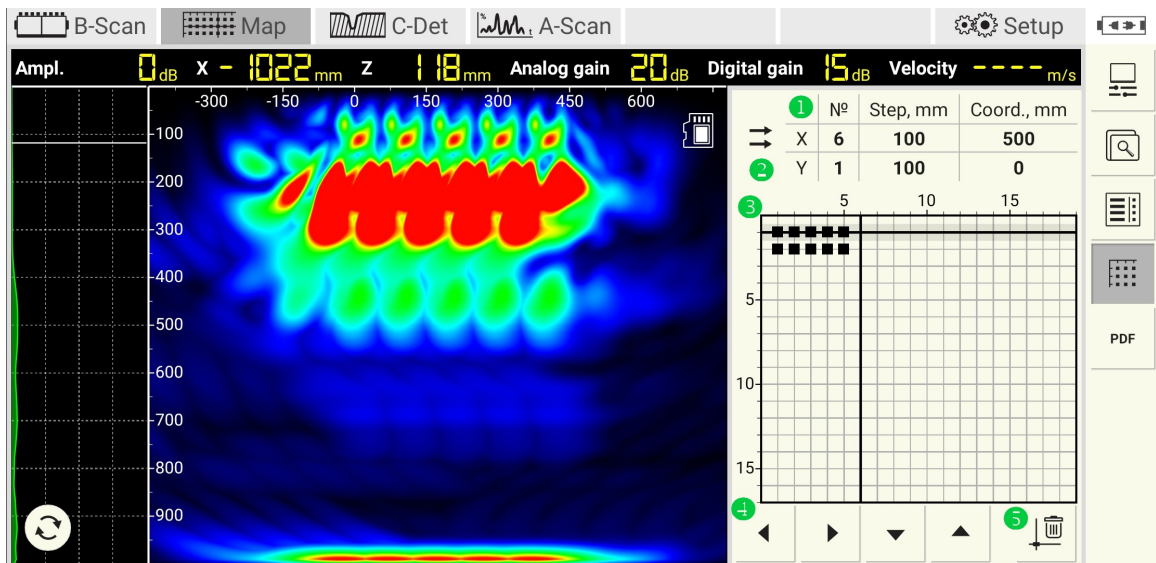

Table 5: Description of parameters

Label	Description
[1]	Table presents main parameters of the map. First column (Number) shows cursor/device coordinates in XY plane. Second column (Step) shows step size along X and Y axis in. Third column (Coord.) shows actual position of cursor/device in XY plane.
[2]	Indicator depicts scanning direction. There are following options: left, right up and down. Operator can setup scanning direction over main parameter tab.
[3]	Map grid indicates position where data were taken. Following actions are available on the map grid: <ul style="list-style-type: none"> • pan grid area. This option can be activated by double click on any free grid space. Hold touch and move a finger to pan • move cursor by touch or arrow control [4] • delete data set at selected position by pressing on trash bin button [5]

20 C-Det

C-Det (*crack detection*) mode allows the operator to evaluate the depth of an open crack.

Parameters

Information panel, main parameters, display parameters as well the file manager are the same as in B-Scan mode. For more information, please, refer to the [chapter ⁴⁸](#).

Important to know about C-Det mode

- The evaluation algorithm requires the crack length on the surface to be larger than 100 millimeters. Otherwise the results might be not reliable.
- C-Det works only in *matrix array* mode. The *array mode* is not available.
- The *automatic velocity calibration* is not active since the surface wave does not propagate through the open crack. The operator is obligated to set the velocity manually.

Measurements with A1040 MIRA 3D

Please, follow these steps:

- Keep attention to the device being placed so that the crack is between the fourth and fifth row of transducers, Figure 8
- Set user-defined velocity. If velocity is not known try to estimate it on crack-free surface or using backwall.

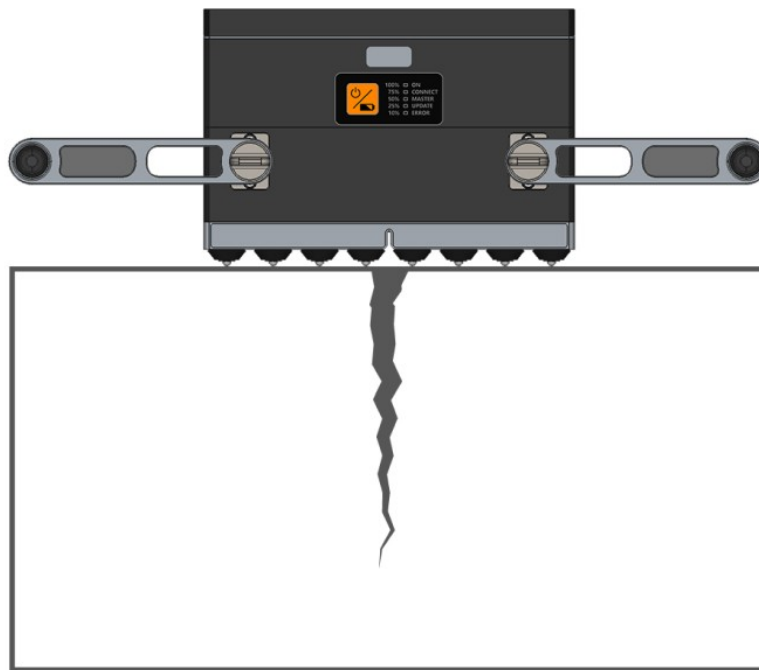

Figure 8: Crack depth estimation with A1040 MIRA 3D

Measurements with A1040 MIRA 3D

Please, follow these steps:

- Keep attention to the device being placed so that the crack is between the eighth and ninth row of transducers, Figure 9
- Set user-defined velocity. If velocity is not known try to estimate it on crack-free surface or using backwall.

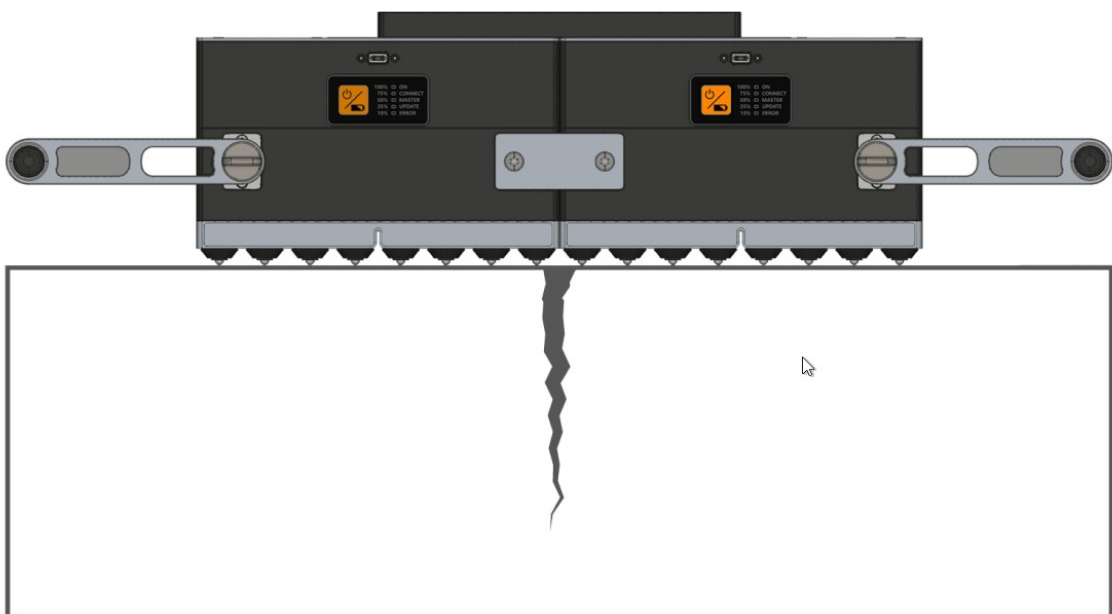
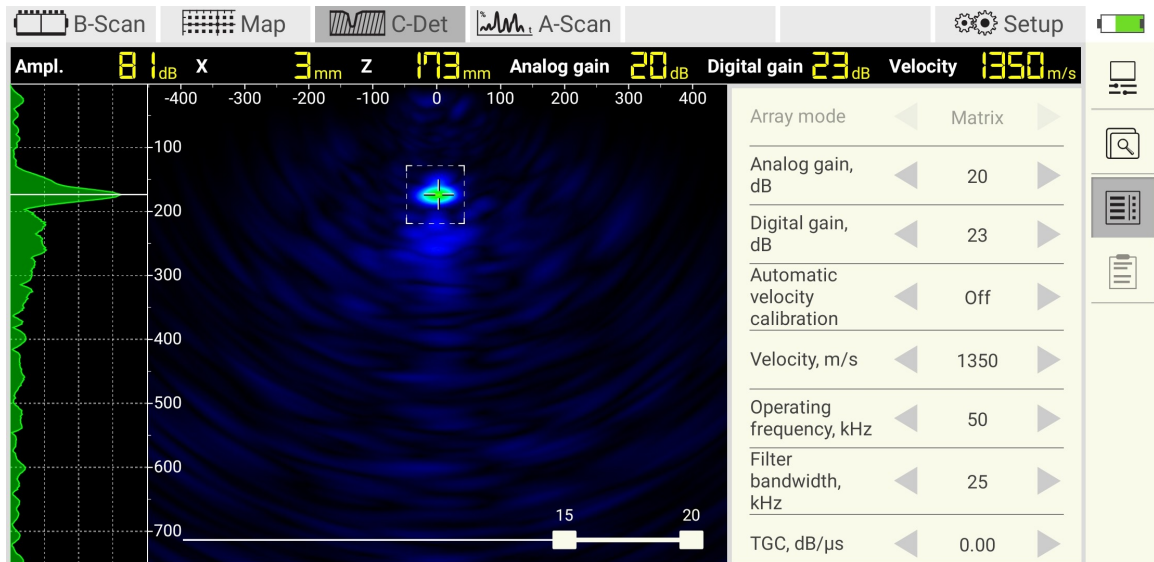

Figure 8: Crack depth estimation with A1040 MIRA 3D PRO**Evaluation****Figure 9: Crack depth evaluation**

- Try to locate the area of interest using the cursor (Figure 9)
- Estimate X and Z location of the crack pitch

21 A-Scan

A-Scan mode allows to perform the following operations: observation of waveform measured by specific transducers; fine tuning of analog and digital gain; analysis of the signal with respect to noise, tuning of TGC, time estimation using gates etc. Main screen of A-Scan mode is given below.

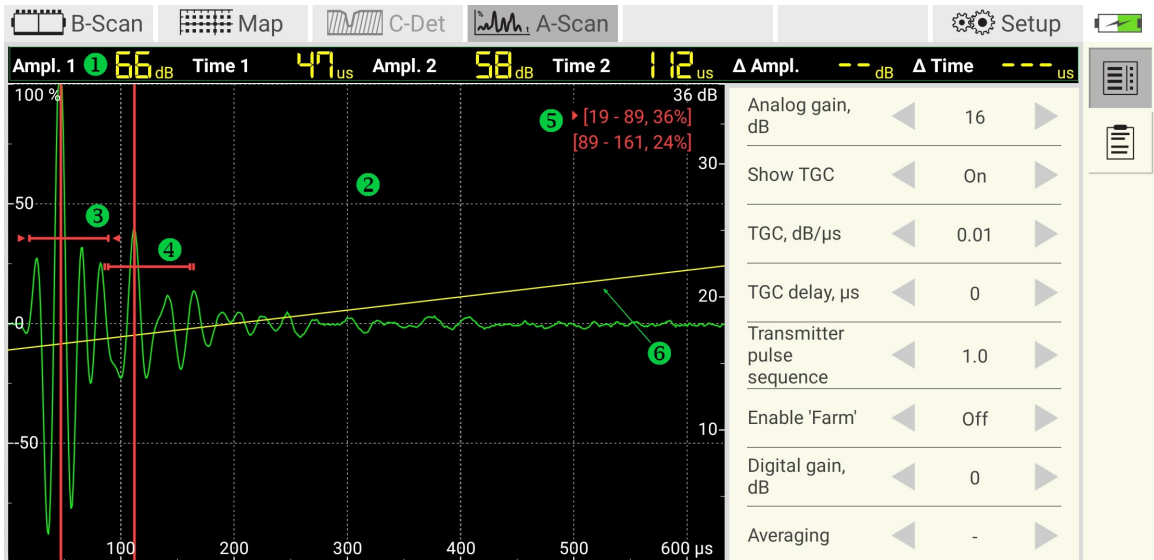











Table 6: Description of controls

ID	Description
1	Main information panel. It shows the following parameters: first/second gate max. amplitude (Ampl1./Ampl2.) in decibel, time of max. detected amplitude (Time1/Time2) in first/second gate, detected amplitude difference (Ampl1-Ampl2.), detected time difference (Time1-Time2)
2	A-Scan view. Double click on A-scan area activates A-scan sub-mode. In this sub-mode operator can pan a-scan horizontally, zoom in, zoom out or reset the view.
3	First gate control. Operator can move gate horizontally or vertically, can increase or shorten gate length. Long press on A-scan area forces gate to appear close to the touch point. Operations with the first gate are available only in first gate sub-mode. In order to switch to first gate sub-mode the operator may click on first gate control or activate first gate sub-mode using active touch control.
4	Second gate control works similar to the first one.
5	The indicator gives the information about the gates. The triangle points to the currently selected gate. The number in brackets introduces the start and the end of the gate expressed in μs. The percentage amplitude follows the comma.

Table 7: Description of parameters

Parameter	Icon	Description
Farm view	-	Refer to the next section.
Averaging	-	Averaging factor can be set to a value from 2 to 16. Software uses averaging factor to compute a-scans from a number of successive following measurements. Averaging can be applied only in A-Scan mode. Set '-' to switch averaging off.
Transmitter	-	Transmitter control allows the operator to select column of transducers in case of linear array mode or single transducer in case of matrix array mode.
Receiver	-	Receiver control allows for the operator to select a receiver which waveform is to be depicted on a-scan.
Active touch		Option activates a-scan sub-mode. Operator can work with a-scan using touch.
		Option activates first gate sub-mode. Operator can work with the first gate using touch
		Option activates second gate sub-mode. Operator can work with the second gate using touch.
Algorithm		Algorithm for amplitude detection: maximum amplitude within first gate. Second gate is off.
		Algorithm for amplitude detection: waveform and gate first crossing within first gate. Second gate is off.
		Algorithm for amplitude detection: difference between maximum amplitudes within first and second gate.
		Algorithm for amplitude detection: difference between amplitudes in the positions where waveform and gates first crossing.
Ascan		Normal waveform representation
		Rectified waveform representation
		Waveform envelope

21.1 Farm View: A1048 MIRA 3D

Enabling the farm view option allows for the operator to show all 32 A-scans on a single graph called `farm view`. Such a bird's-eye view may help to diagnose the device for broken transducers, electronic failure, environmental noise distortions. The operator can use the `farm view` in both `linear` or `matrix` array mode.

Transducer assignment

The A1040 MIRA 3D addresses the transducer with a column and a row number separated by a dot, for example, `column.row`. The transducer with a minor address `1.1` has its position at the upper left corner of the instrument. The column number increases from left to right. The row number increases from up to down, see Figure 10.

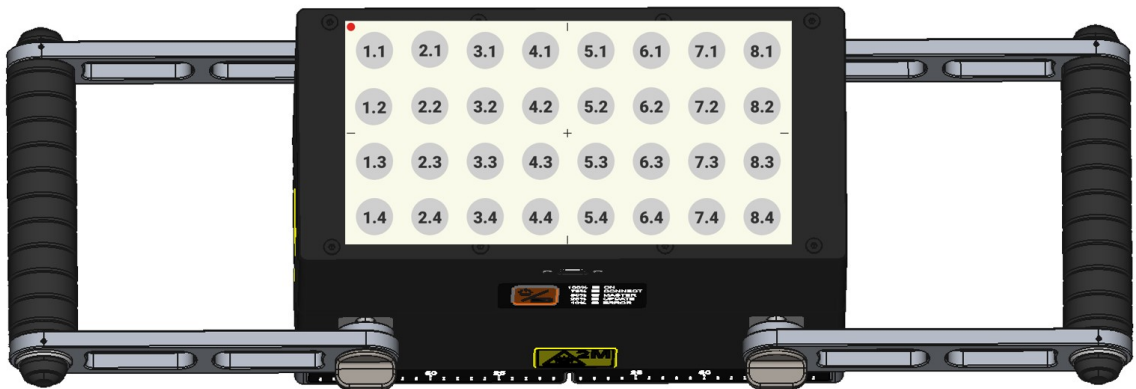

Figure 10: Transducer assignment scheme

Linear mode

In the linear array mode ①, the operator can select a group of four transmitting transducers. Tap on the transmitter control ②. Select the group (or column) of transmitters in the rising dialog. Transmitters become black ③. The receiver ④ has a red border (Figure 11).

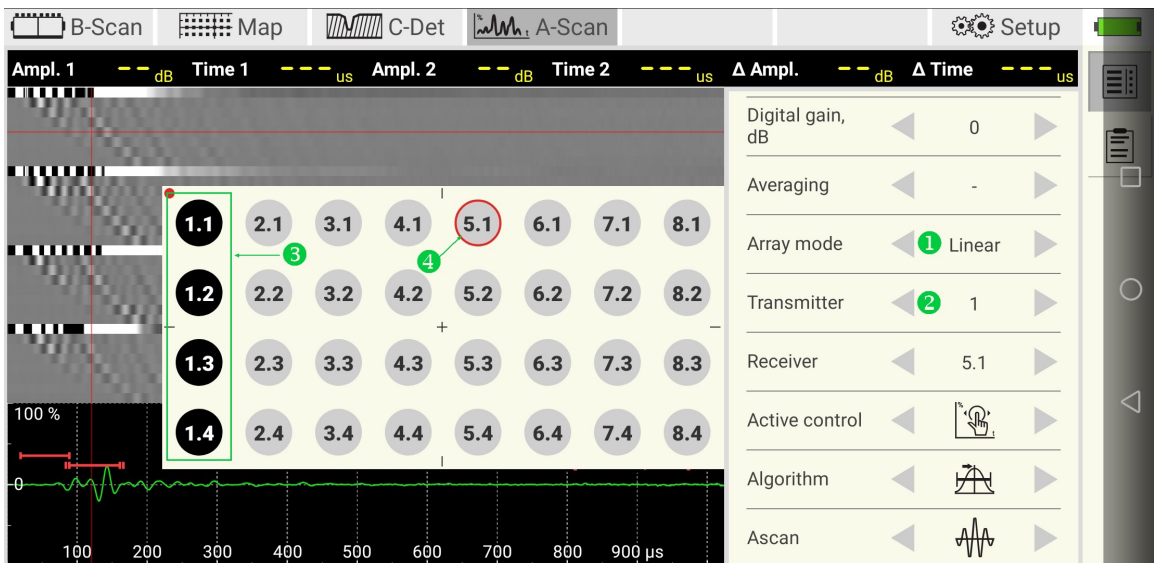

Figure 11: Selecting the group of transmitters

Figure 12 illustrates the receiver selection. Use the control u to assign the receiver. The rising dialog indicates the receiver by black color v and transmitters with a red border w. Alternatively, the receiver can be selected with the help of the horizontal cross cursor x. Activate the cursor by long tap on farm view or using y. Select the desired a-scan (the corresponding receiver will be shown in u) by moving the cursor vertically.

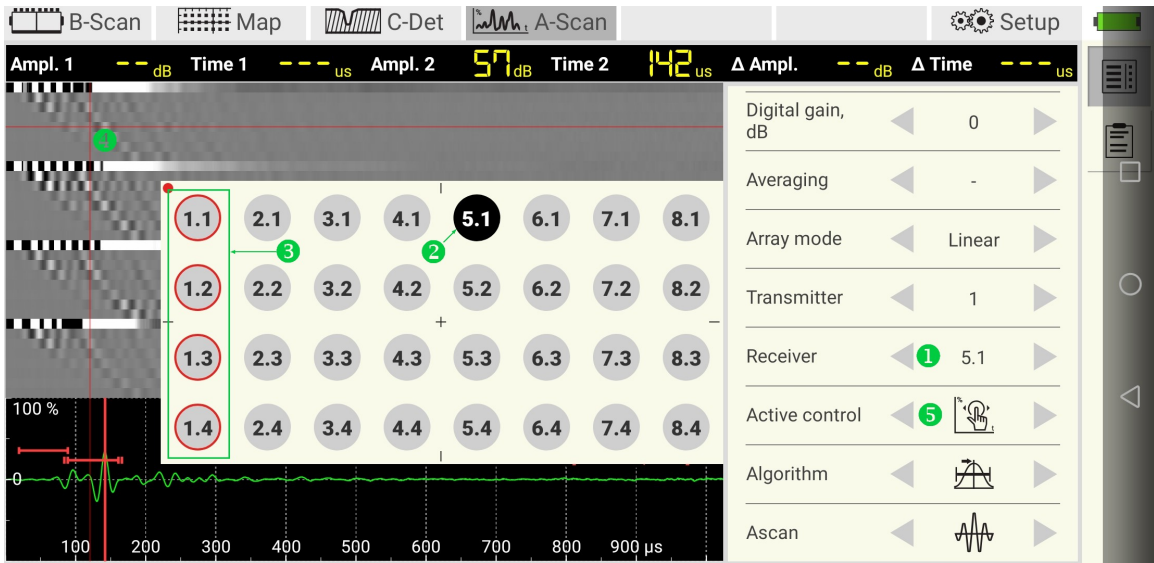

Figure 12: Receiver selection

Matrix mode

In the *matrix* mode, the operator can select rather a single transmitter than a group ① (Figure 13). Receiver selection flow does not change.

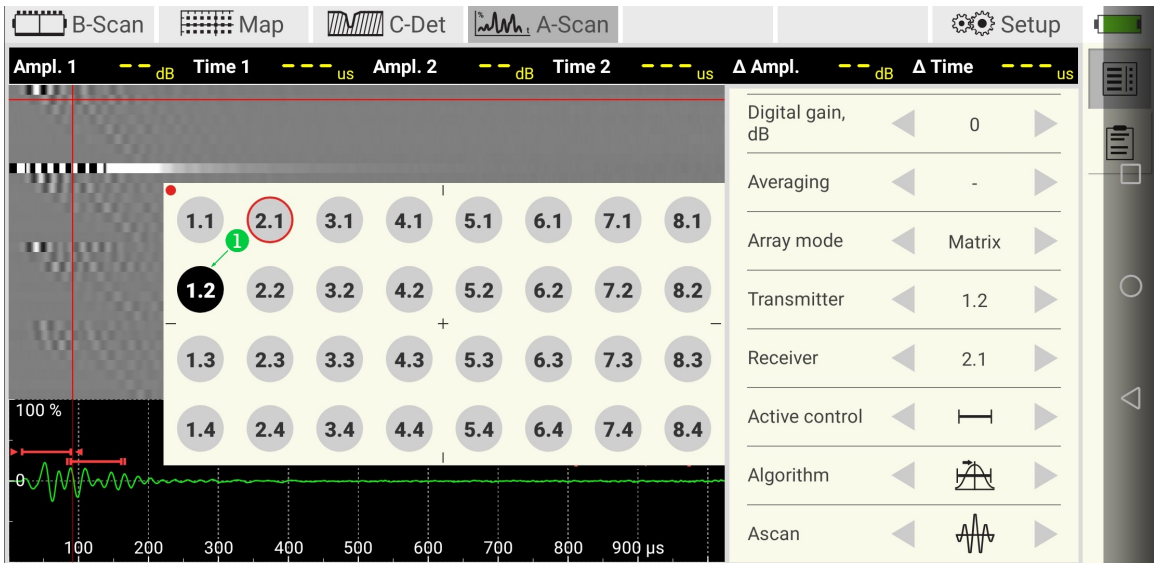

Figure 13: Selecting a transmitter in matrix mode

21.2 Farm View: A1048 MIRA 3D PRO

The farm view of A1040 MIRA 3D PRO works equally to the farm view of A1040 MIRA 3D. The A1040 MIRA 3D PRO addresses the transducers of the master **[M]** and the slave **[S]** throughout (see Figure 14 ① and ②). Thus, all the 64 transducers may work independently as transmitters or receivers, separately or in groups.

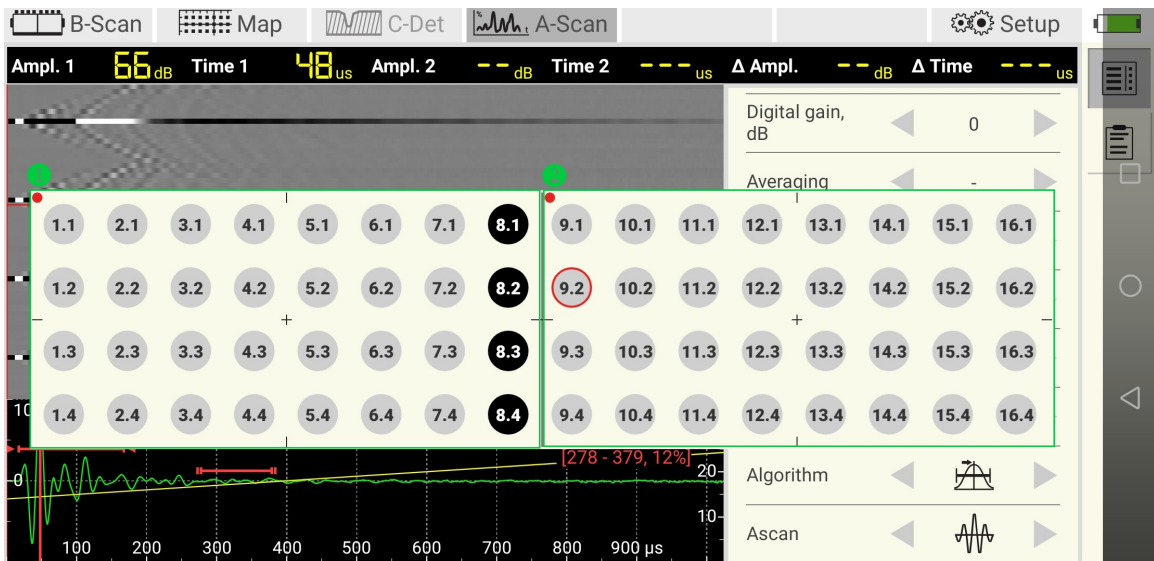

Figure 14: Selection a group of transmitters in linear mode

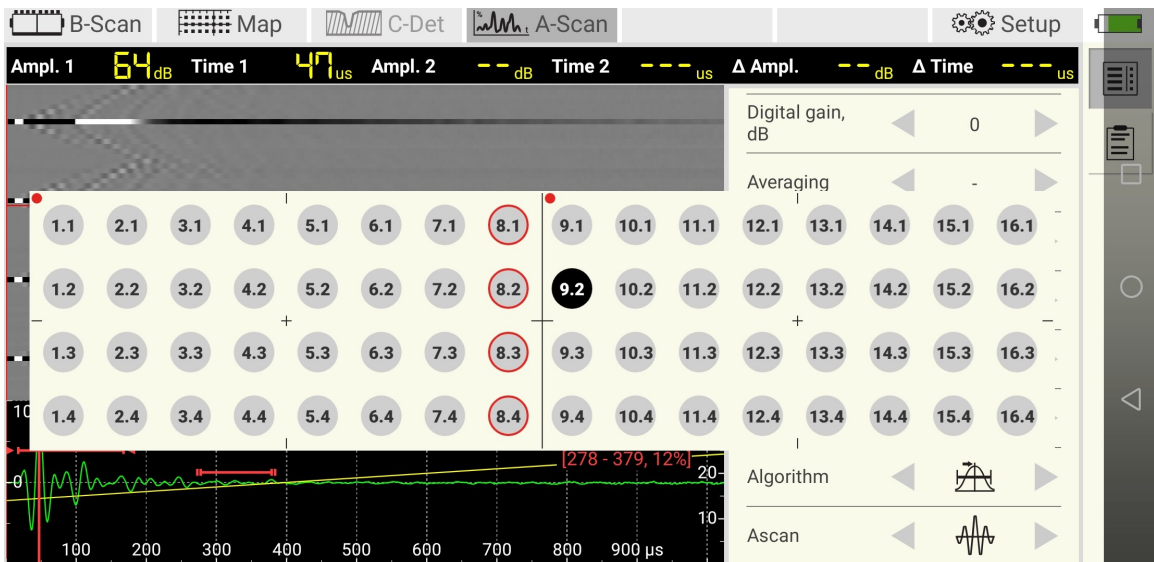

Figure 15: Selecting the receiver in linear mode

22 Reporting

The reporting function provides some tools for creation, management and sharing of the reports. B-Scan, MAP, C-Det and A-Scan modes support reporting.

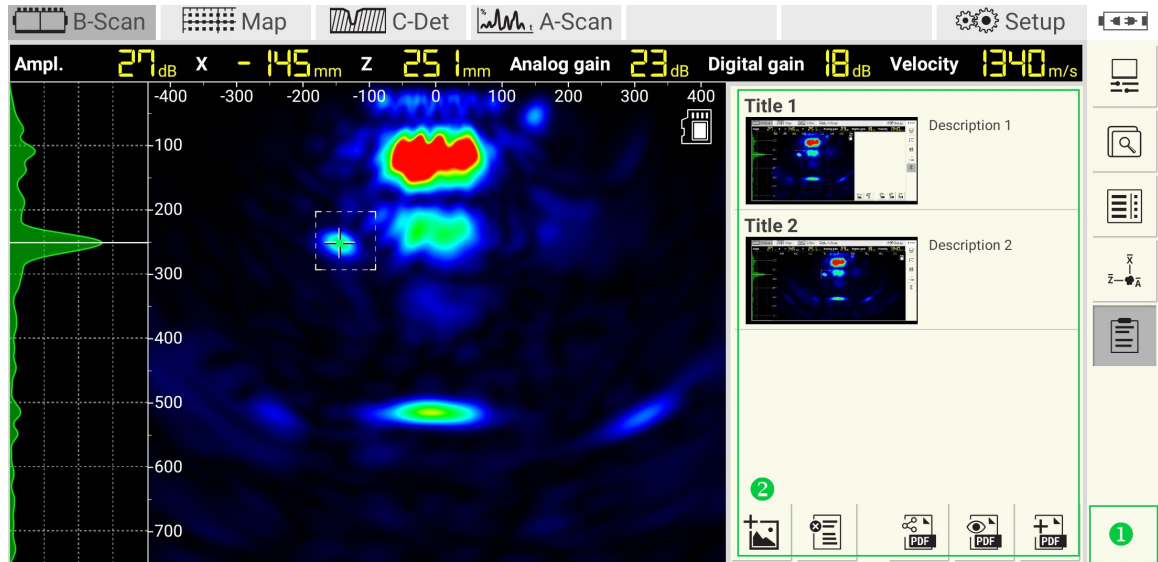

Figure 16: Report screen

Reporting tools

The following table lists the available reporting tools.

Icon	Description
	Generate report. After editing the report, use this tool to regenerate it. The app raises a dialog window while creating a pdf file.
	Show report. Use this tool to open a pdf file with a pre-installed pdf-reader.
	Share report. After pressing the icon, the android operation system offers to choose a third-party sharing software. It can be an email client, a cloud or any messenger. Install the sharing software before using the report.
	Clear report. After pressing the tool deletes all report screenshots.
	Add image. The tool adds an image from the gallery. The operator may enter a title and a description.

Taking a screenshot

Take a screenshot by holding the finger on the active area **1** for about one second. This area is available at any time, whether panel **2** is open or closed. Every time starting the application, the android operation system asks for permission for taking screenshots. Confirm the rising dialog with *START NOW*:

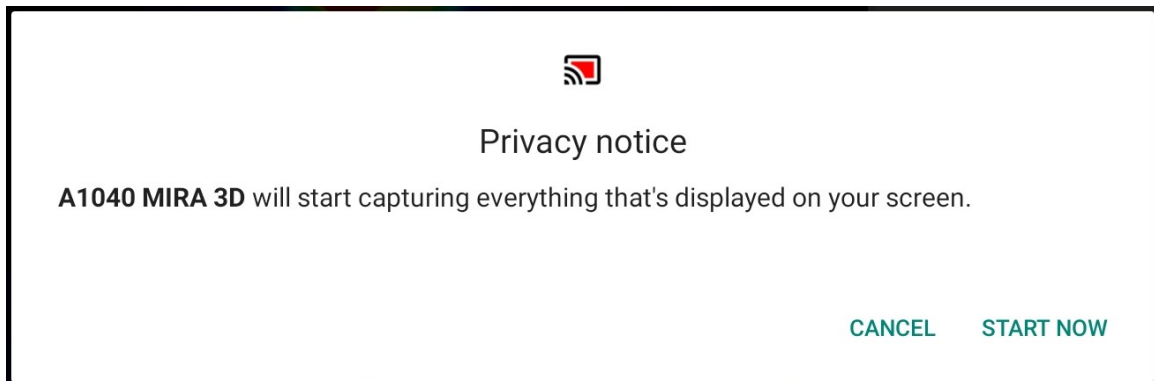

Editing a screenshot

The operator may edit the title and the description of the screenshot at any time. The editing dialog has fields ❶ and ❷ for that. Use the keyboard ❸ for typing, Figure 17

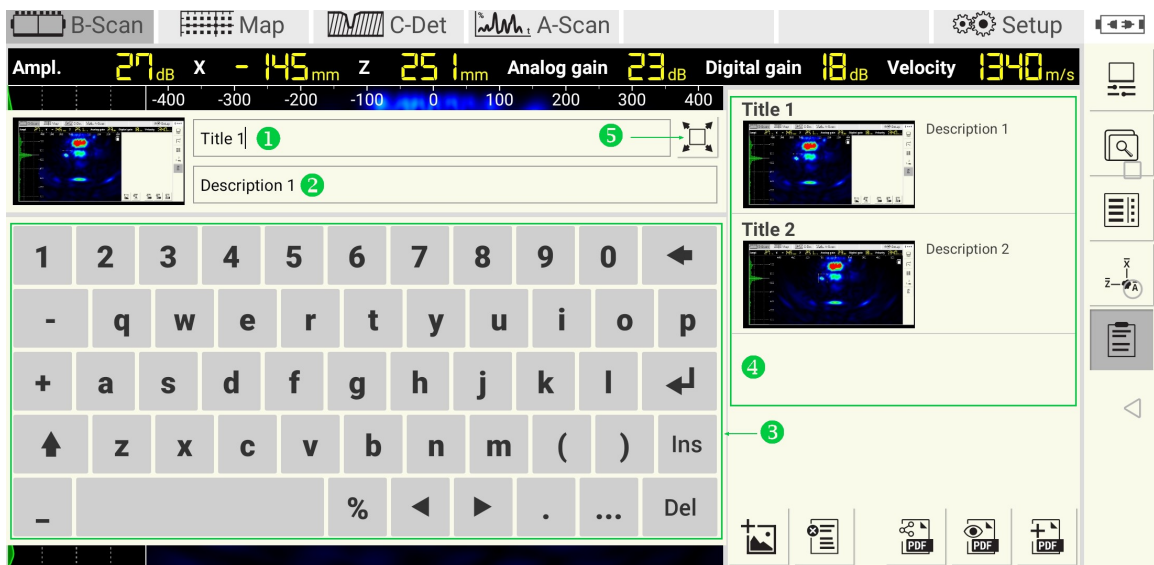



Figure 17: Screenshot editing

Confirm the changes with  to add screenshot to the list ❹. Use the zooming tool ❺ for enlarging the screenshot.

After pressing the zoom  button The fields title and description become uneditable, Figure 18. Use the unzooming tool ❶ to switch to the previous view.

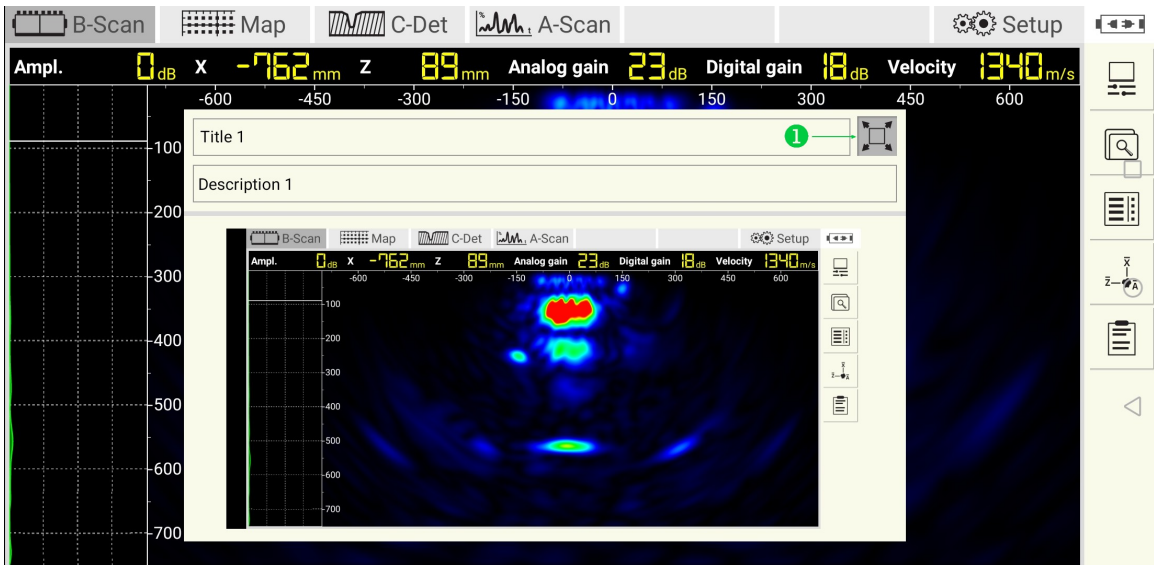

Figure 18: Screenshot zooming

List of screenshots

Delete a screenshot from the list by swiping the item from right to left, see ① on Figure 19. While swiping, the basket is going to replace the item. Confirm the deleting with YES or abort with NO.

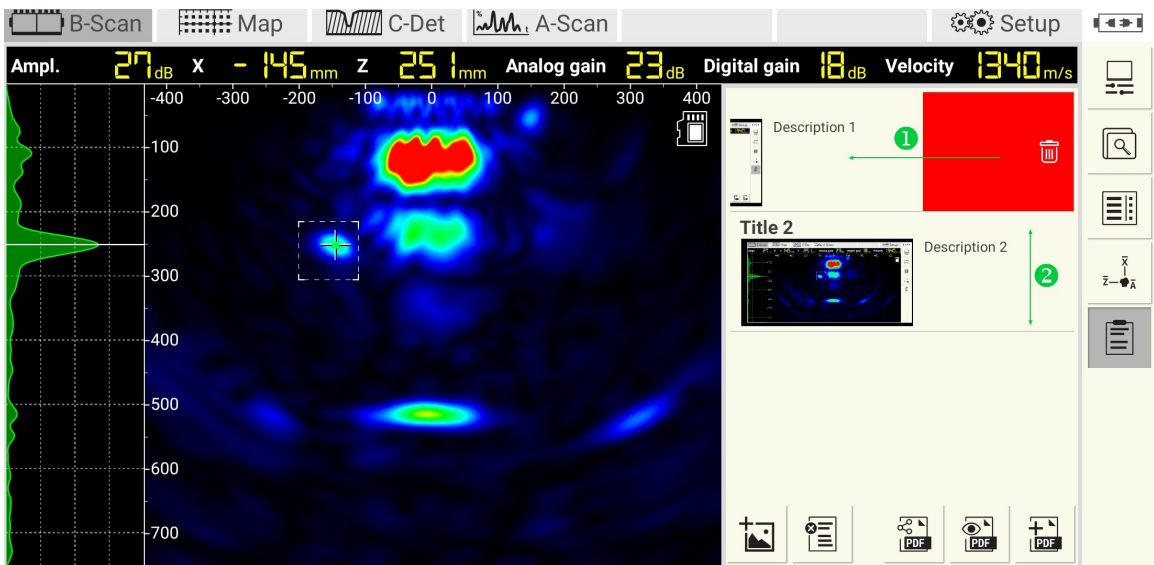

Figure 19: Working with list of screenshots

Scroll the list vertically to find the desired item (see ②). Change position of the item in the list using drag&drop.

23 Setup

Setup mode allows the operator to adjust system parameters, scan for online devices, configure the instrument, set master and slave instruments, and carry out transducer self-test.

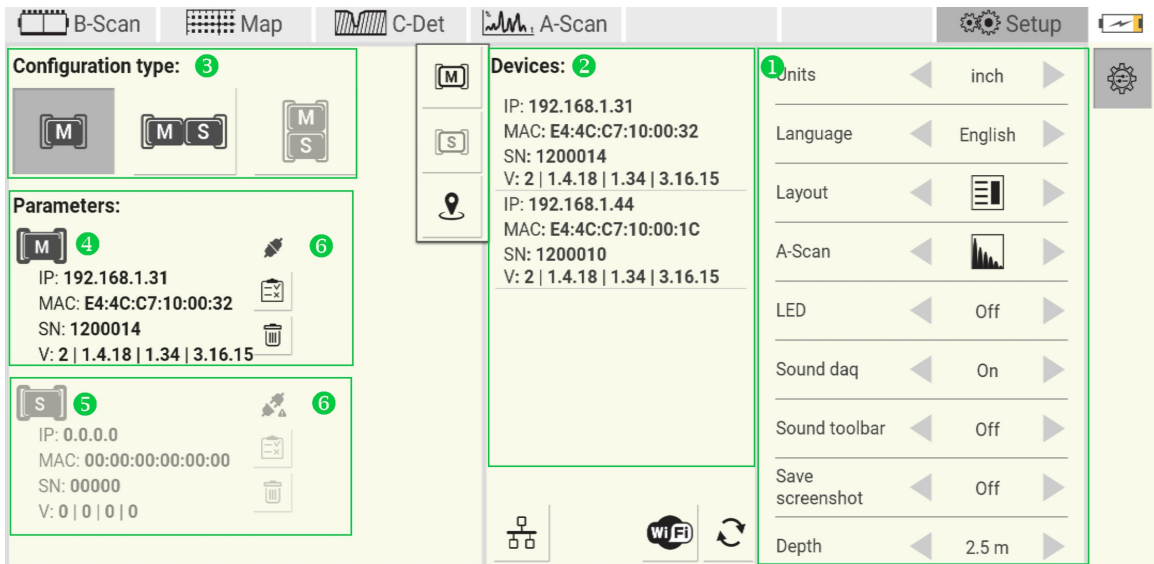

Table 20: : Description of elements





















ID	Description
①	System parameters panel. Description of parameters see in the table below
②	Device panel lists online instruments found during the scanning process. The App reads and shows system information that includes: IP address given by the access point, MAC address, instrument serial number and firmware version number. Double click on a found instrument rises a pop up menu with three options described described in this table.
	Sets instrument as master. Current master will be overridden.
	Sets instrument as slave. Current slave will be overridden.
	Button initiates I'm here feature. By tapping it the operator forces the selected device to blink by its master LED
	Button initiates reconnection of tomographs for a defined configuration the selected configuration type. Use this routine if the automatic connection fails.
	The button demonstrates the status of the WiFi connection. The icon  stands for the error-free state. In case of any error or any warning, the icon  changes to the icon  . Read a detailed description of this button in the section below.
	Button calls scanning for online instruments
③	Instrument configuration section. The operator can specify one of the following configurations: A1040 MIRA 3D  or A1040 MIRA 3D PRO  . The configuration A1040 MIRA 3D PRO  is currently not available.
④	Sub-panel informs the operator about current settings for the master
⑤	Sub-panel informs the operator about current settings for the slave
⑥	Indicator shows whether the master/slave is currently connected. The indicator has two states: disconnected  and connected 
	Button calls a routine for the transducer test. Detailed description of the transducer test procedure is given on page 79 .
	Button removes the current instrument from the list



Table 8: Description of parameters

Parameter	Icon	Description
Units	-	Switches between metric or non-metric units
Language	-	Switches user interface language
Layout		Parameter selects right hand side location of the app control panel
		Parameter selects left hand side location of the app control panel
A-Scan		A-Scan is plotted as empty waveform
		A-Scan is plotted as filled waveform
LED	-	Switches the device's laser pointers on/off
Sound daq	-	The app informs operator about finalizing daq by sound signal when switched on
Sound toolbar	-	If turned on, the app confirms parameter changes with sound signal.
Save screenshot	-	If turned on, the app saves a jpeg-screenshot with each measurement.
Depth	-	The depth parameter defines the required inspection depth. There are three options available: 1.25m, 2.5m and 3.5m. The smaller the inspection depth is, the faster is transmission speed over WiFi. If it is possible, reduce the depth to speed up the instrument in matrix mode.
Free space	-	See description below
Version	-	App release version

WiFi state indicator

The WiFi state indicator informs the operator about the state of the WiFi

connection. The icon  appears if the instrument is online. Thus, the operator may configure the instrument and work normally (refer to the [page](#))⁷⁵.

The icon  appears if the Tablet-PC cannot establish the connection with the instrument's WiFi. By clicking on  the operator may receive one of the following dialogs:

- Location permission dialog. Press **1** to close the dialog and continue work offline (without the instrument). Press **2** and follow the instruction to switch on the location.

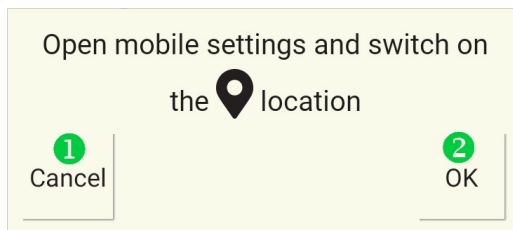

- WiFi connection request. Press ① to close the dialog and continue work offline (without the instrument). Press ② and follow the instructions for establishing the connection with the instrument's WiFi. If the instrument is off, refer to the [page](#) to prepare the instrument for work.

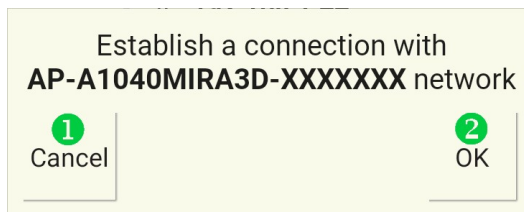

Free space

The value shows the amount of available internal memory. If there is less memory than 250MB, a warning message appears.

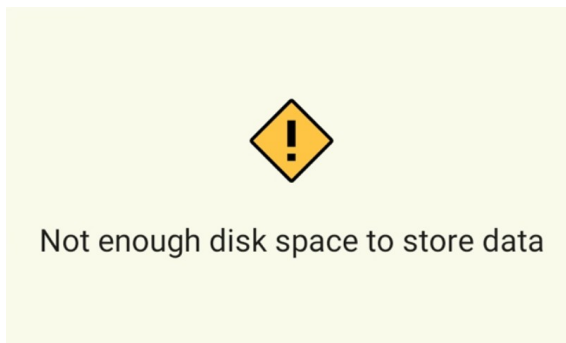

In this case the app allows measurements in B-Scan and C-Det modes but prohibits saving any B-Scan or C-Det data. Both measuring and saving of a MAP are not available.

23.1 Instrument configuration

After the app installation or re-installation, the operator must configure the instrument. The configuration is also necessary if the operator plans to change the configuration type between A1040 MIRA 3D and A1040 MIRA 3D PRO.



23.1.1 A1040 MIRA 3D

To configure A1040 MIRA 3D follow the following steps.

Step 1

Prepare the instrument following the steps given on the [page](#)⁹⁸. These include powering on the device, establishing the connection with the instrument's WiFi, and opening the app.

Step 2

Open `setup` mode and assure yourself the WiFi indicator **1** shows the icon . If the indicator shows icon , refer to [page](#)⁷² for solving the issue.

Step 3

Press button  to scan for available instruments. Scanning process will be indicated with the progress indicator **2**.

Step 4

After the scan finishes, the `device list` **3** shows all available devices. Select A1040 MIRA 3D-configuration **4** and tap on a device item **5** to assign it as a master , Figure 21.

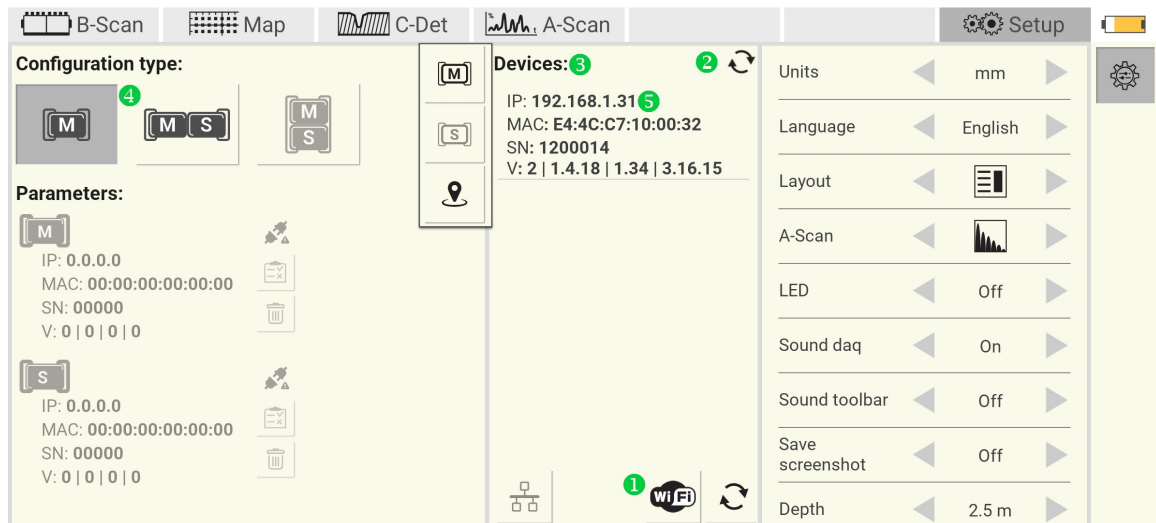







Figure 21: A1040 MIRA 3D configuration

NOTE

If the `device list` encounters more than one instruments use button  to distinguish one instrument from another. After pressing , the selected instrument starts blinking with MASTER LED.

Step 5

After successful connection the panel ① shows parameters of the master device. The indicator ② changes from  to . The battery indicator ③ changes its status from disconnected  to power, Figure 22.

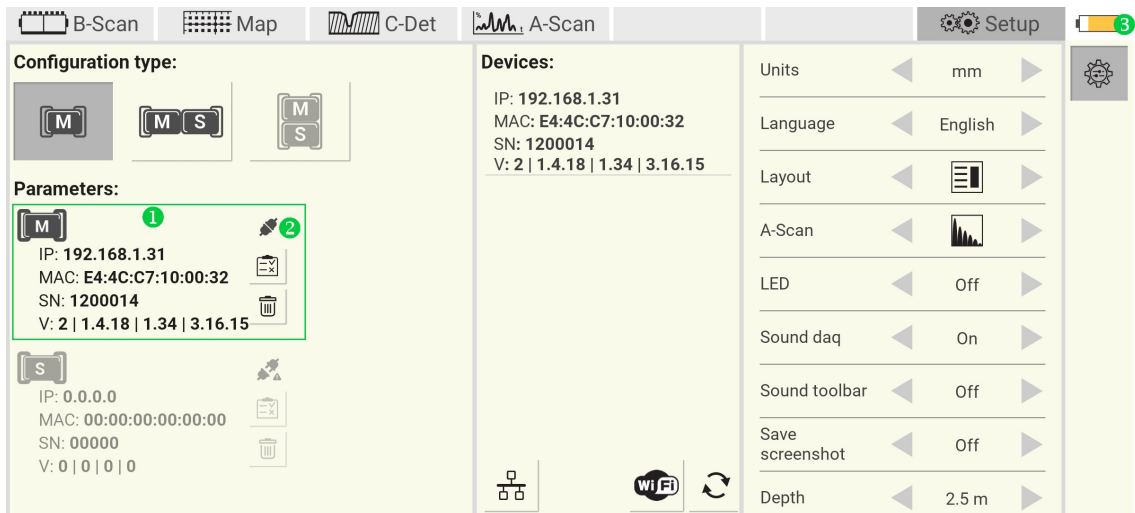

Figure 22: A1040 MIRA 3D connection

23.1.2 A1040 MIRA 3D PRO

The tomograph configuration follows the mechanical assembly of the instrument described on [page 12](#).



WARNING

The master instrument feeds the synchronization signal to the slave over H-fasteners ①. The polarity of the wiring is of great importance. Keep in mind the master is always on the left if the keypad looks towards you, Figure 9

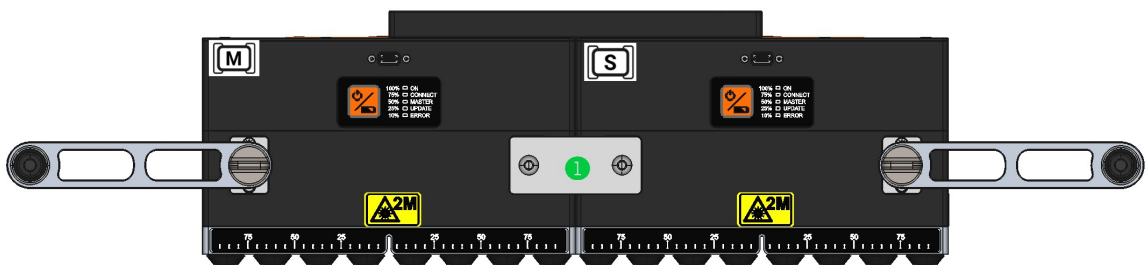

Figure 23: Master and slave synchronization



CAUTION

Before starting the configuration of the A1040 MIRA 3D PRO refer to the configuration details of A1040 MIRA 3D given on the [page 75](#).

A1040 MIRA 3D PRO configuration

Switch on the tomograph, establish the connection to the hotspot and start the app. After the scan finishes, the device list **1** shows all available devices. Select A1040 MIRA 3D PRO-configuration **2** and tap on a device item **3** or **4** to assign the device as a master **[M]** or as a slave **[S]**, Figure 24.

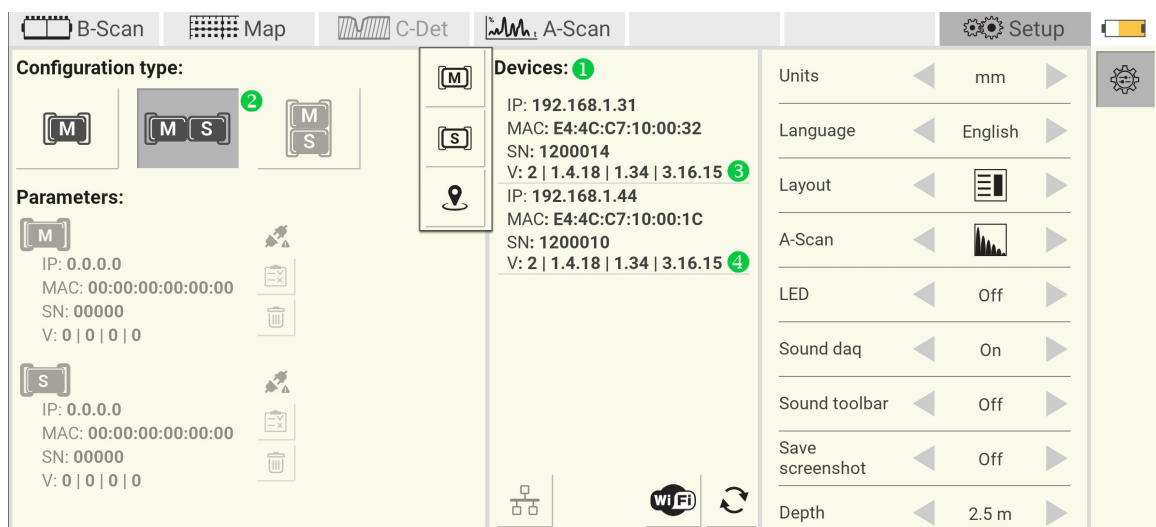





Figure 24: A1040 MIRA 3D PRO configuration

After successful connection the panel **1** shows parameters of the master and the slave devices. The indicators **2** change from  to . The battery indicator **3** changes its status from disconnected  to power, Figure 25.

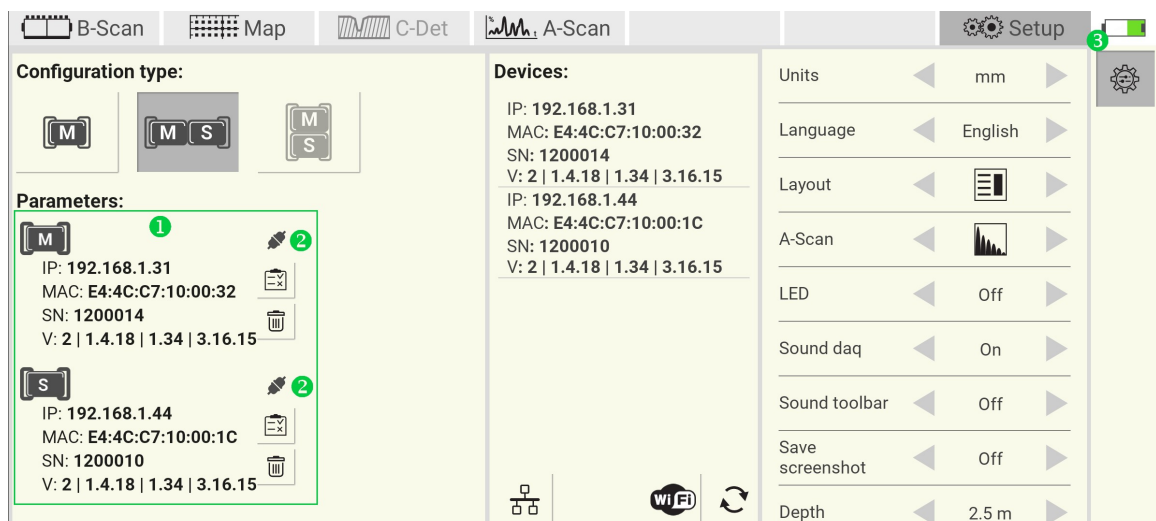

Figure 25: A1040 MIRA 3D PRO connection

23.2 Automatic transducer testing

The delivery kit includes a `test block`. The block is a plexiglass plate with a slightly rough surface. It is used to perform the functionality test of each array transducer.

23.2.1 A1040 MIRA 3D

This section describes the step-by-step procedure for transducer testing of A1040 MIRA 3D.

Step 1

Put the sample on a flat, dry and stable surface.

Step 2

Switch on the tomograph, establish the connection to the hotspot and start the app. Refer to the details for the `getting started` procedure on [page 98](#). Open `setup` mode and configure the instrument as master.

Step 3

Activate the `testing procedure` by pressing the  button. After activation the app shows the following window. Put the instrument on the sample and press it firmly.

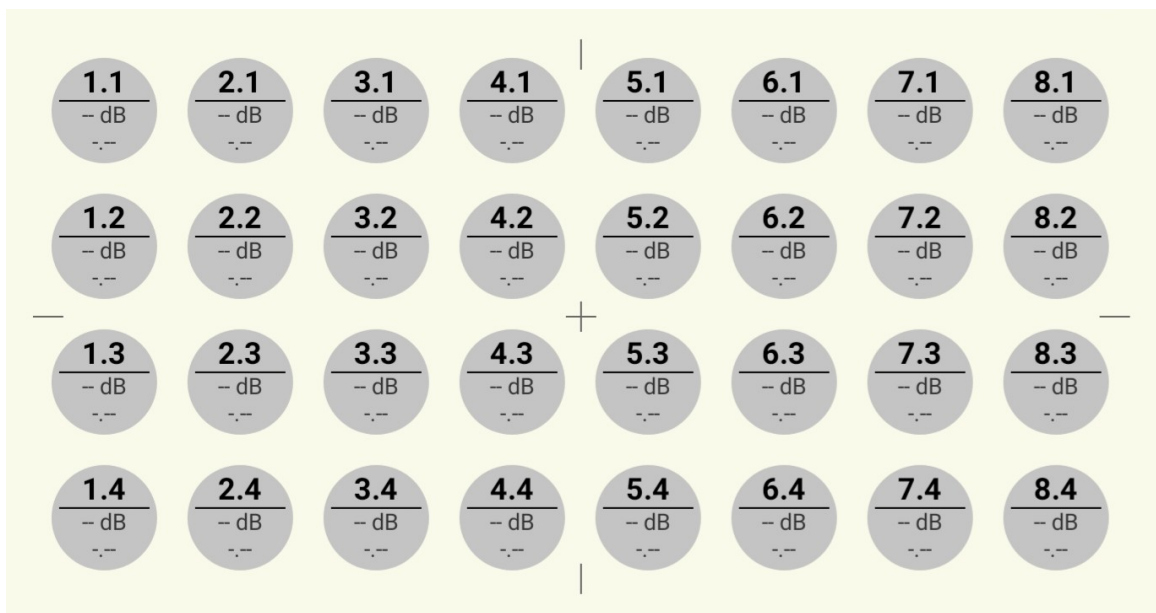

Step 4

Press any `data collection` button located at one of the handles of the tomograph. After pressing the button the tomograph starts scanning. The dialog looks as follows.

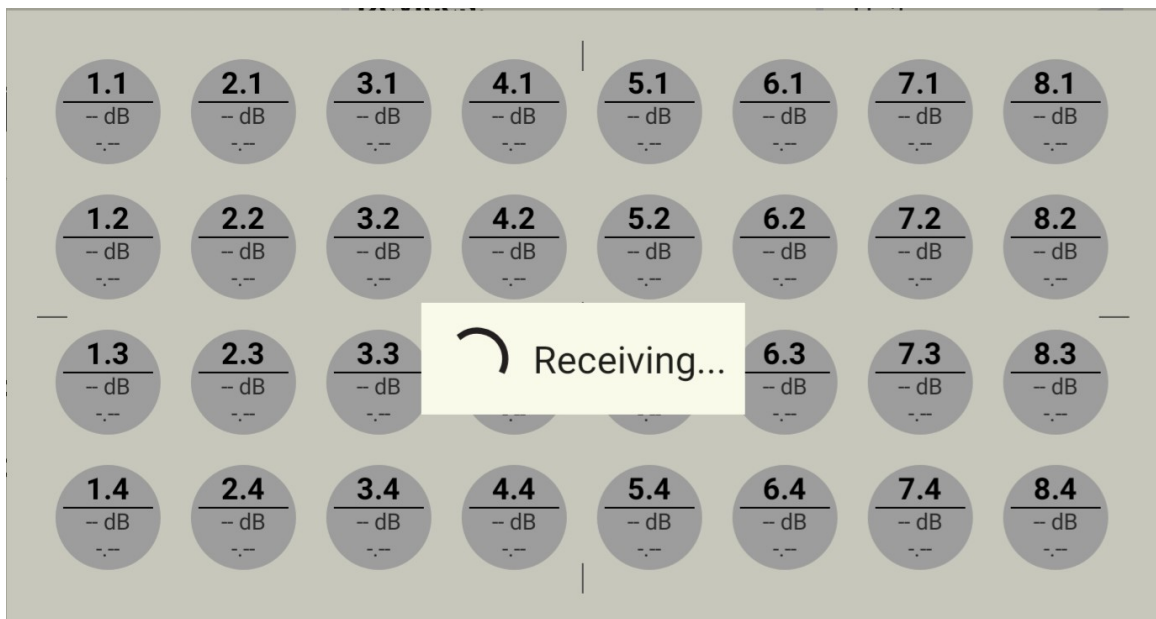

Step 5

In case of a successful test the transducers will be colored green. This means, that the tomograph is ready to use.



In case of an error a transducer will be colored red.

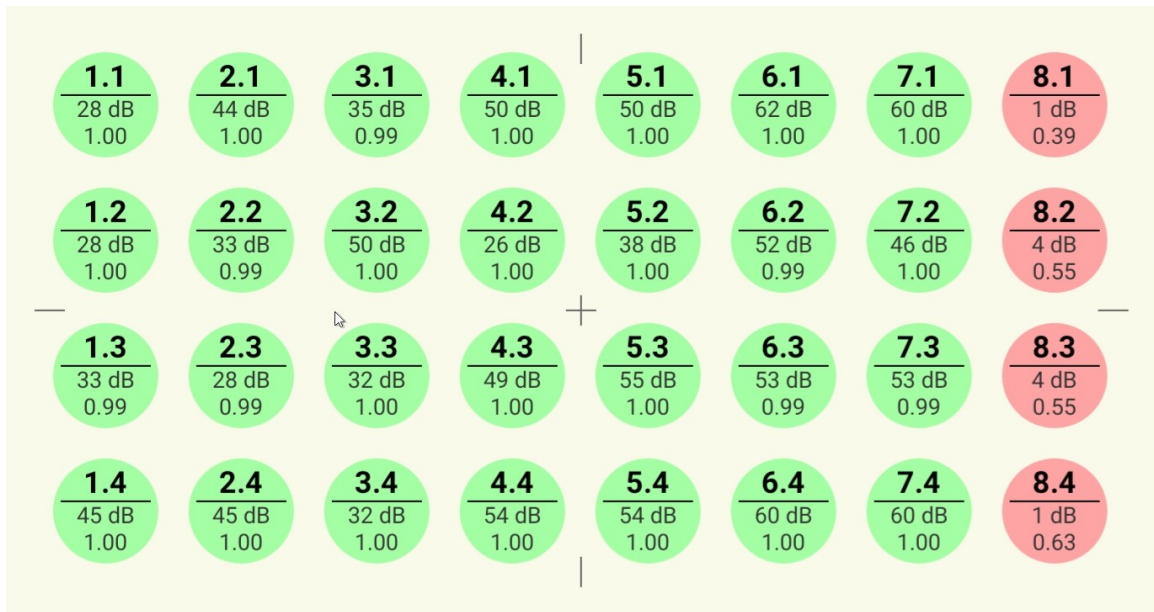

In this case it is necessary to contact the manufacturer service center by e-mail at info@acs-international.com or by phone: +49 681-9659-2270.

23.2.2 A1040 MIRA 3D PRO

NOTE











The transducer testing of the master and the slave of A1040 MIRA 3D PRO is independent. Carry out the procedure described on the [page 79](#) to test the master and the slave. The A1040 MIRA 3D PRO is ready to work only if both the master and the slave passed the test.

24 Powering

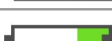

The app observes the battery state of the instrument and the Tablet-PC.

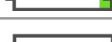
Charge level indicator

The `charge level indicator` at the right top of the screen shows the level of the battery charge and whether it is charging. The indicator takes one of the states represented by the following icons:

Symbol	Description
	remaining charge 100%
	remaining charge 90%
	remaining charge 80%
	remaining charge 70%
	remaining charge 60%
	remaining charge 50%
	remaining charge 40%
	remaining charge 30%
	remaining charge 20%
	remaining charge 10%
	instrument is not connected
	instrument is charging

NOTE

The indicator shows charge level of both the instrument and the Tablet-PC. The indicator changes the color between  (the instrument) and  (the Tablet-PC) every 5 seconds.

NOTE

A warning message appears if the charge level of the instrument or/and the Tablet-PC is less than 10%. The message pops up every 3 minutes:

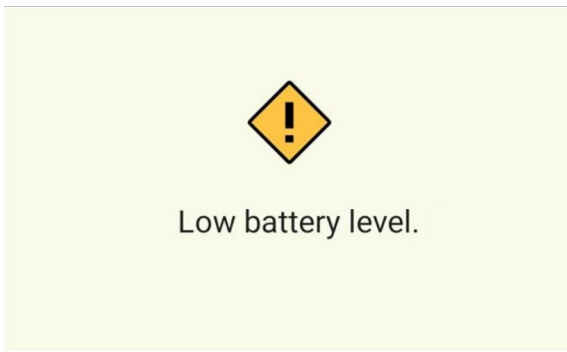

Charge level information window

Open the charge level information window by single taping on the charge level indicator.

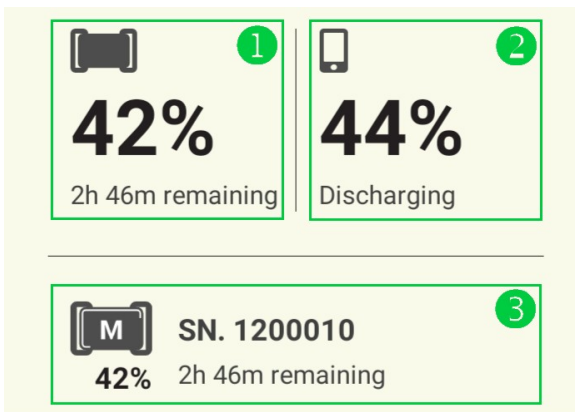

Label	Description
①	<p>Instrument section. It shows the remaining charge level of the instrument. The text field takes one of the following values:</p> <ul style="list-style-type: none"> • Xh Ym remaining - time to full discharging • Approx. Xh until fully charged - time to full charging • -h -m - waiting for condition information. It takes some time for the app to read the charge level from the instrument. You may see this text if you just established connection with the Tablet-PC, connected or disconnected charging cable. Wait for about 1 minute and try to open the window again.
②	<p>Table-PC section. It shows the remaining charge level of the Table-PC. The text field takes one of the following values:</p> <ul style="list-style-type: none"> • Discharging - discharging is in process • Charging (Ac) - charging over the power charger • Charging (Usb) - charging over USB interface
③	<p>Instrument section. This section shows the charge level state of the master and the slave. In the case of A1040 MIRA 3D, section ③ shows the same information as section ① (only the master is present). In the case of A1040 MIRA 3D PRO, this section lists the charge levels of both the master and the slave. But section ① takes the worst charge level in respect to operation time.</p>

25 Connectivity

This chapter describes details on different connection types of A1040 MIRA 3D and A1040 MIRA 3D PRO.

25.1 WiFi access point concept

Access point concept

The instrument itself act as the access point (i.e. the instrument is a WiFi source).

The A1040 MIRA 3D with a serial number 1200XXX (which is master **[M]**) creates a WiFi network with the name AP-A1040MIRA3D-1200XXX. The operator ensures the connection of the Tablet-PC with the instrument's network. In the case of A1040

MIRA 3D PRO, both the master **[M]** and the slave **[S]** create their WiFi networks. However, the slave automatically connects to the master's access point. The operator must only ensure the connection of the Tablet-PC with the master's WiFi. To read more about A1040 MIRA 3D PRO refer to the [page](#)¹³.



CAUTION

The A1040 MIRA 3D and the A1040 MIRA 3D PRO leave the factory fully assembled and ready to work. The operator can see the WiFi networks after powering on the instrument.

When the WiFi configuration is required

NOTE

For carrying out the updates you need a Windows PC

If required, the operator can do the WiFi configuration of the A1040 MIRA 3D or the A1040 MIRA 3D PRO. There are three cases when the WiFi configuration is needed:

- the manufacturer requests the operator to reconfigure WiFi in the scope of updates or other activities
- the operator configures A1040 MIRA 3D PRO out of two A1040 MIRA 3D
- the operator configures two A1040 MIRA 3D out of A1040 MIRA 3D PRO

25.2 WiFi configuration of a master

WiFi configuration of a master **[M]** includes following steps:

- Download, unpack and install (if the program has not yet been installed) the A1040MIRA3D_wlan_configuration, use download link on [page 116](#) for FILE1
- Power off the instrument, refer to the [page 98](#)
- Connect the supplied USB cable to the Windows PC TYPE A plug, refer to the delivery scope on the [page 12](#)
- Power on the instrument and wait until the LED "UPDATE" starts blinking.
- Within the next 5 seconds (While LED "UPDATE" is blinking), connect the USB cable to the instrument TYPE C plug. The UPDATE indicator is constantly on now.
- Launch the A1040MIRA3D_wlan_configuration.exe and press "Configure WiFi Settings" button ①



- Wait until the program detects the instrument as a drive ① and press "Next" ②

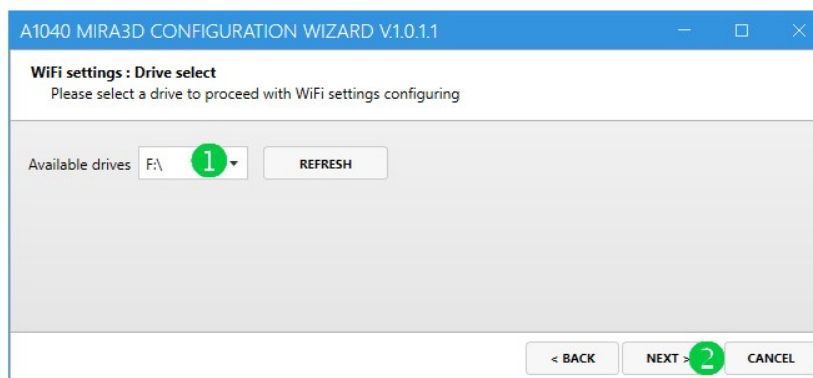

- Select Router/Master (AP-A1040) ① network type, select your region ②, set radio band to 5 GHz ③, set WiFi channel at Auto ④ and press "Next" ⑤

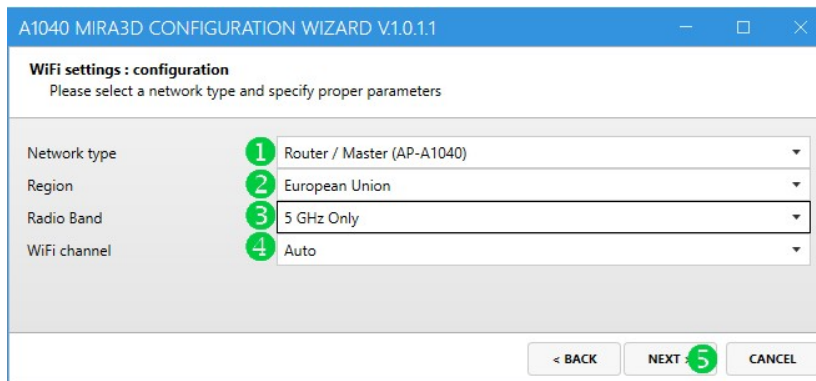

- Check the settings and press "Next" ①

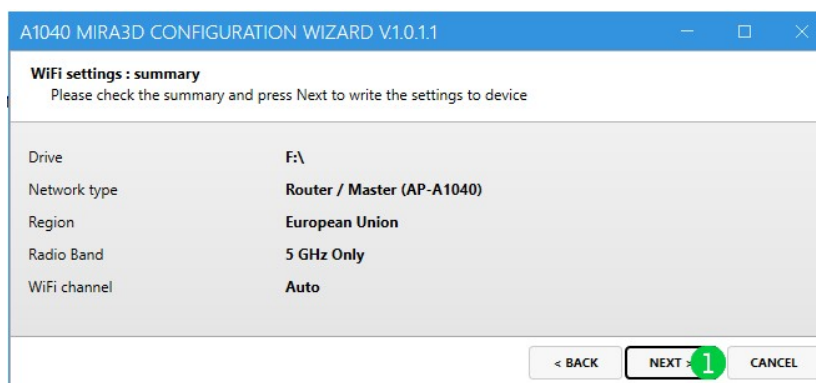

- Wait until LED "UPDATE" stops blinking and press "OK" ① to confirm

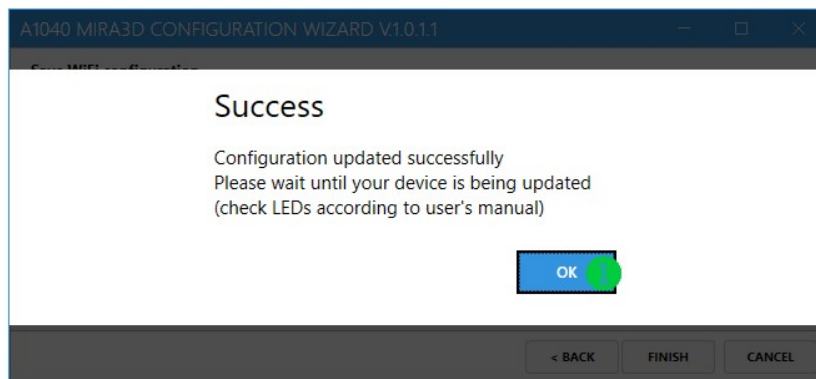

- Press ① close the program

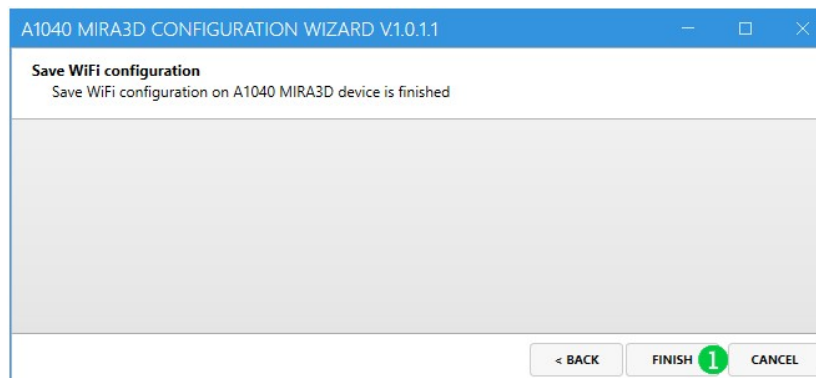

- Disconnect the A1040 MIRA 3D from the PC

- Power off the instrument

25.3 WiFi configuration of a slave

WiFi configuration of a slave **[S]** includes following steps:

- Download, unpack and install (if the program has not yet been installed) the A1040MIRA3D_wlan_configuration, use download link on [page 116](#) for FILE1
- Power off the instrument, refer to the [page 98](#)
- Connect the supplied USB cable to the Windows PC TYPE A plug, refer to the delivery scope on the [page 12](#)
- Power on the instrument and wait until the LED "UPDATE" starts blinking.
- Within the next 5 seconds (While LED "UPDATE" is blinking), connect the USB cable to the instrument TYPE C plug. The UPDATE indicator is constantly on now.
- Launch the A1040MIRA3D_wlan_configuration.exe and press "Configure WiFi Settings" button **1**

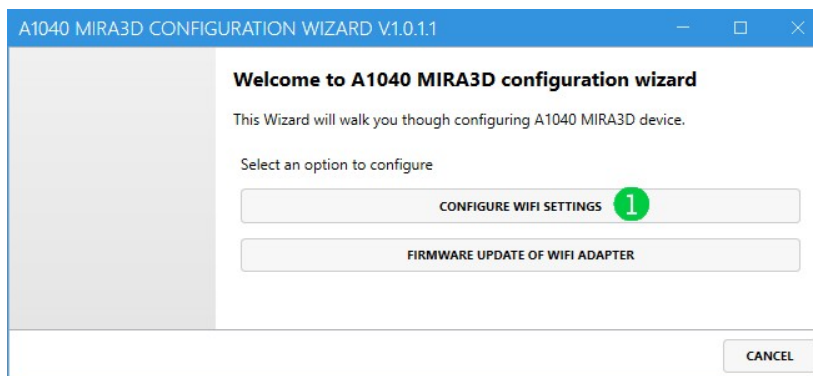

- Wait until the program finds appropriate drive, select a drive using **1** and press **2**

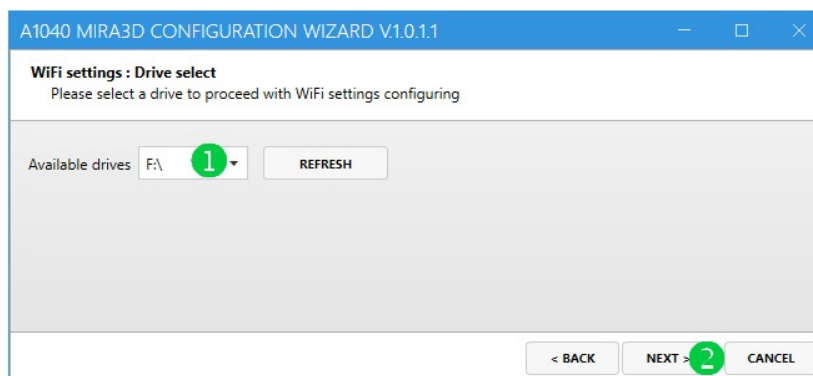

- Select Client/Slave **1** network type, select your region **2**, set radio band to 5 GHz **3**, set WiFi channel at Auto **4** (these parameters must be the same as by the master **[M]**). Last three characters of the Router's serial are those of

the master's **[M]** serial (see device identification sticker [page 10](#)) **5**. Set AP mode = on **6** and press "Next" **7**. Read more about **[M]** and **[S]** on the [page 13](#).

A1040 MIRA3D CONFIGURATION WIZARD V1.0.1.1

WiFi settings : configuration
Please select a network type and specify proper parameters

Network type	1 Client / Slave
Region	2 European Union
Radio Band	3 5 GHz Only
WiFi channel	4 Auto
Router's serial (last 3 digits)	5 1200 001
AP Mode	6 On

< BACK NEXT 7 CANCEL

- Check the settings and press "Next" **1**

A1040 MIRA3D CONFIGURATION WIZARD V1.0.1.1

WiFi settings : summary
Please check the summary and press Next to write the settings to device

Drive	F:\
Network type	Client / Slave
Region	European Union
Radio Band	5 GHz Only
WiFi channel	Auto
Router's serial	1200001

< BACK NEXT 1 CANCEL

- Wait until LED "UPDATE" stops blinking and press "OK" **1** to confirm

A1040 MIRA3D CONFIGURATION WIZARD V1.0.1.1

Success

Configuration updated successfully
Please wait until your device is being updated
(check LEDs according to user's manual)

OK 1

< BACK FINISH CANCEL

- Press **1** close the program

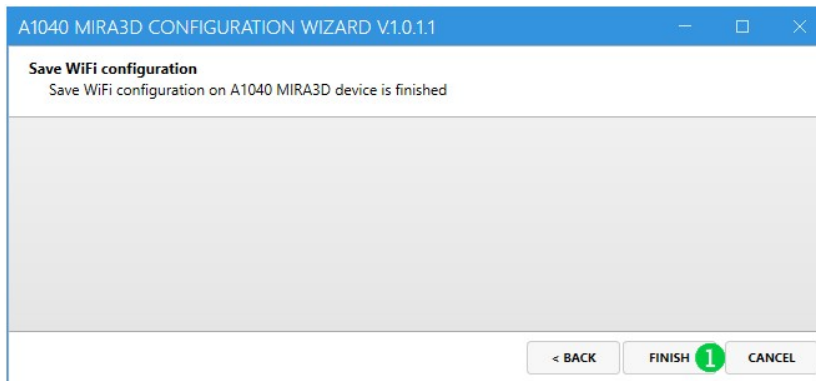

- Disconnect the A1040 MIRA 3D from the PC
- Power off the instrument

25.4 WiFi module firmware update



WARNING

Update the firmware only when required by the manufacturer.

- Download, unpack and install (if the program has not yet been installed) the A1040MIRA3D_wlan_configuration, use download link on [page 118](#) for FILE1
- Power off the instrument, refer to the [page 98](#)
- Power on the instrument and wait until the LED "CONNECT" starts blinking.
- Launch the A1040MIRA3D_wlan_configuration.exe and press "Firmware update of WiFi adapter" 1

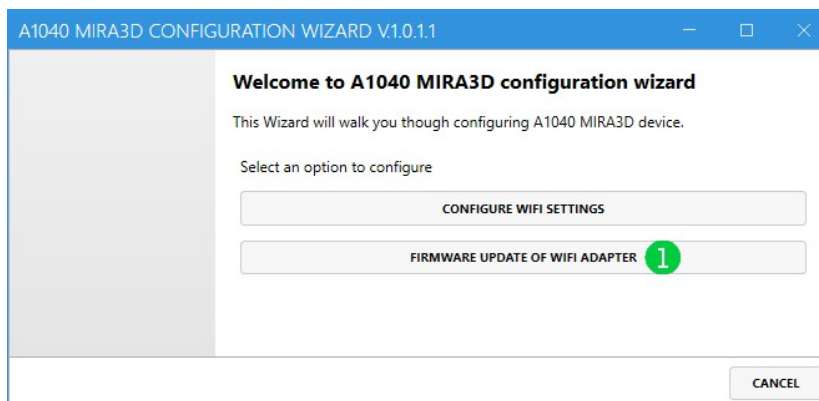

- Select desired WiFi interface with 1 and press "Next" 2

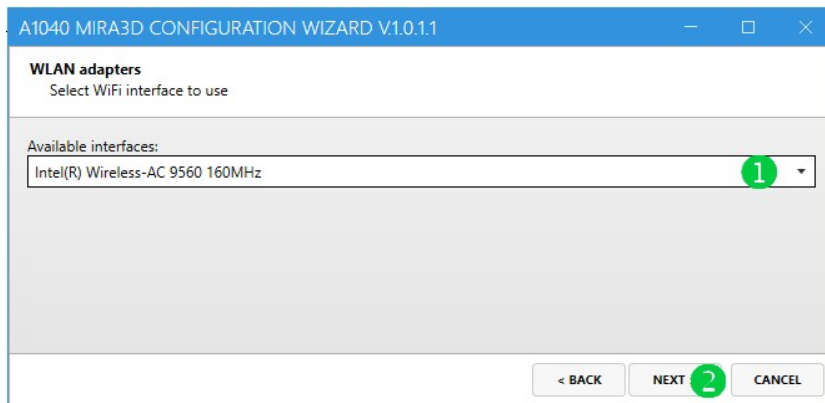

- Wait during the program scans for available networks

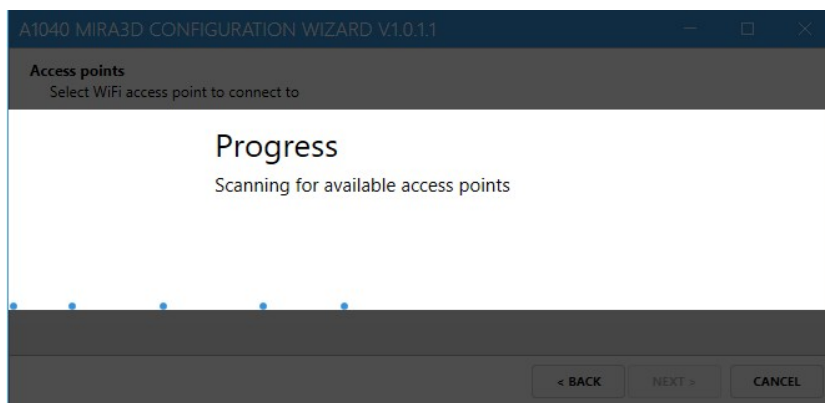

- Select a network of the instrument to be updated **1**. Check the serial number. Press "Next" **2**

NOTE

If `A1040MIRA3D_wlan_configuration` can not detect the proper access point, power the instrument off, close the configuration program, and start the firmware update procedure again.

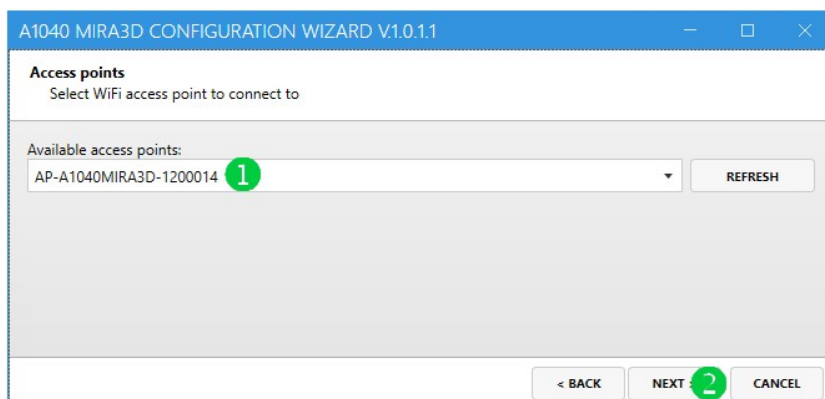

- Wait until the program connects to the network

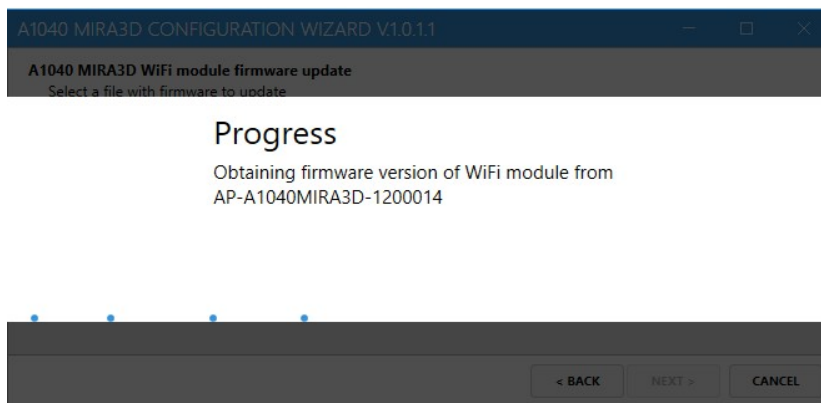
**NOTE**

If A1040MIRA3D_wlan_configuration can not read the firmware version, press "OK" then press "BACK" and repeat the previous step

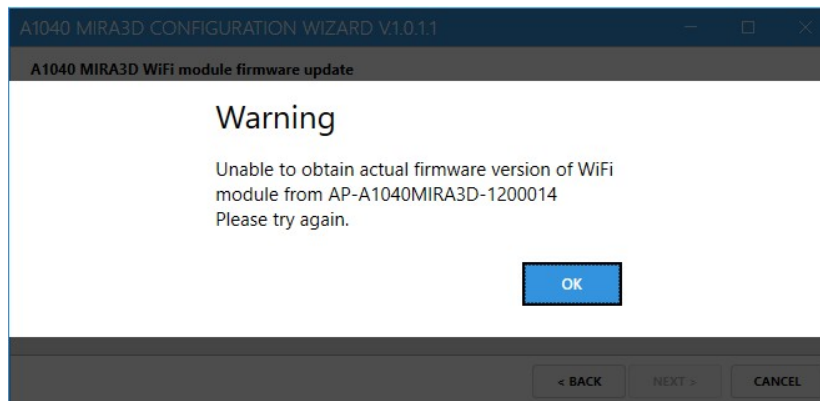

- Browse using ① the rom-file, which is inside of unpacked A1040MIRA3D_wlan_configuration folder. Select the rom-file and "Next" ② to continue.

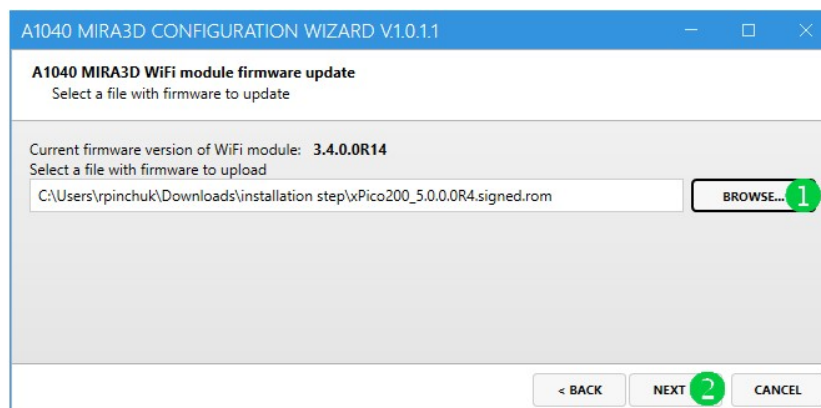

- Wait until the program finishes the firmware update

**WARNING**

The update takes several minutes. DO NOT close the configuration program. DO NOT power the instrument off. Otherwise, the instrument may become undetectable.

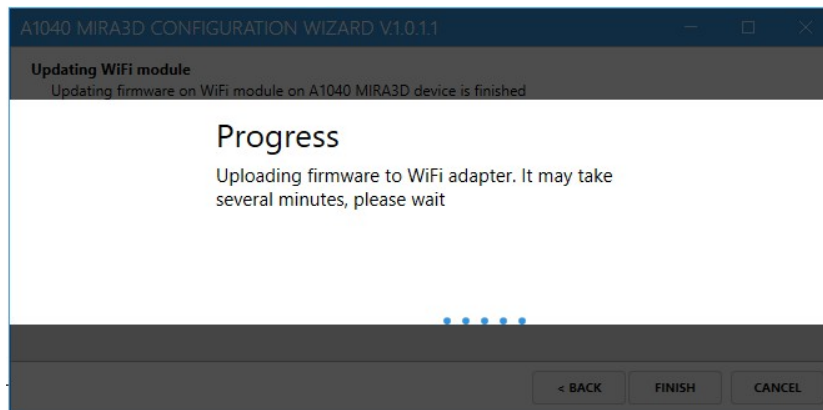

- Press "OK" ① to confirm

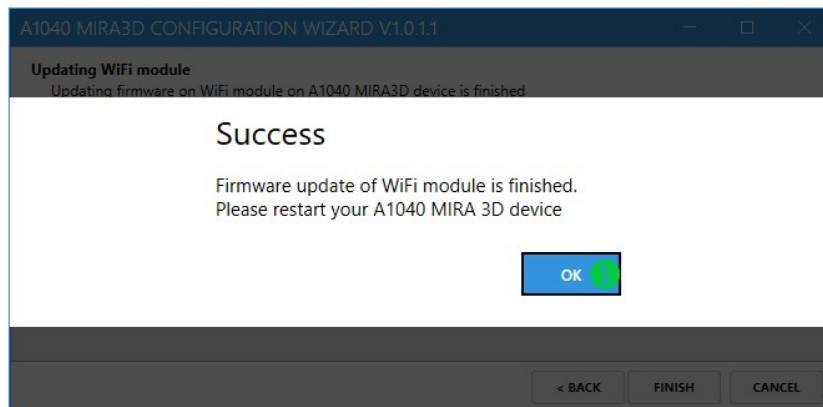

- Press ① close the program

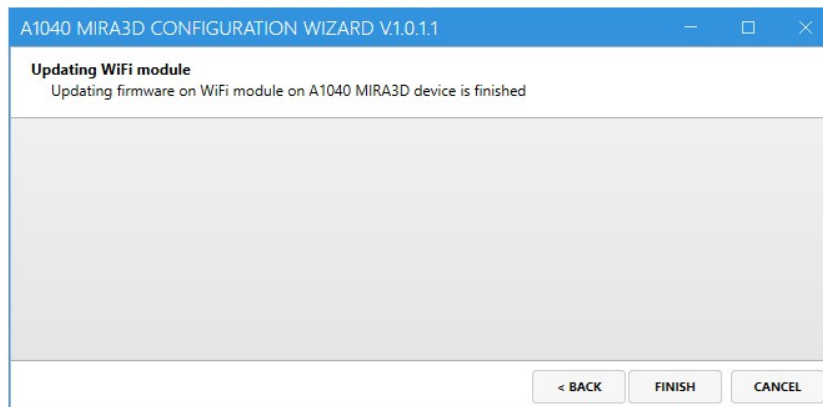

- Power off the instrument

25.5 Migration from Hotspot to WiFi

The Hotspot connection technology finds perennially lesser support starting at 11th and higher Android versions. To improve user's experience, the A1040 MIRA 3D and the A1040 MIRA 3D PRO utilize the classical WiFi interface. The Hotspot technology will not be further supported for the A1040 MIRA 3D and the A1040 MIRA 3D PRO.

IMPORTANT

To ensure error-free functioning of the instrument, ACS requests to migrate all the A1040 MIRA 3D and the A1040 MIRA 3D PRO dispatched from ACS head office in Germany before 1. of January 2022. Refer to the [Migration procedure](#) section below.



TUTORIAL-3 on the [page](#)^[116]

Migration procedure

1. Download the latest Firmware from ACS service [here](#)
2. Install the Firmware: see the section [Firmware update](#) on [page](#)^[99]
3. Prepare your WiFi module for the firmware update. Carry out the steps at the section [Preparation of WiFi module for update](#) below
4. Update the WiFi module firmware, refer to the [page](#)^[90]
5. Configure the master instrument **[M]** refer to the [page](#)^[85]
6. Configure the slave instrument **[S]** refer to the [page](#)^[88]
7. Install the latest app from the download page [here](#) (refer to the chapters [App installation](#) and [App activation](#) on [page](#)^[101] and [page](#)^[102])
8. Read chapter [Preparation for Work](#) on [page](#)^[98] to start working with the instrument.

Preparation of WiFi module for update

- Download, unpack and install (if the program has not yet been installed) the `A1040MIRA3D_wlan_configuration`, use download link on [page](#)^[116] for FILE-1
- Power off the instrument, refer to the [page](#)^[98]
- Connect the supplied USB cable to the Windows PC TYPE A plug, refer to the delivery scope on the [page](#)^[12]

- Power on the instrument and wait until the LED "UPDATE" starts blinking.
- Within the next 5 seconds (While LED "UPDATE" is blinking), connect the USB cable to the instrument TYPE C plug. The UPDATE indicator is constantly on now.
- Launch the A1040MIRA3D_wlan_configuration.exe and press "Configure WiFi Settings" button ①

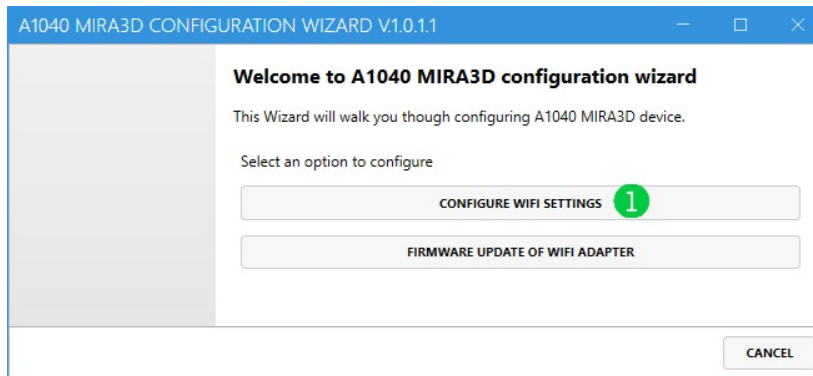

- Wait until the program detects the instrument as a drive ① and press "Next" ②

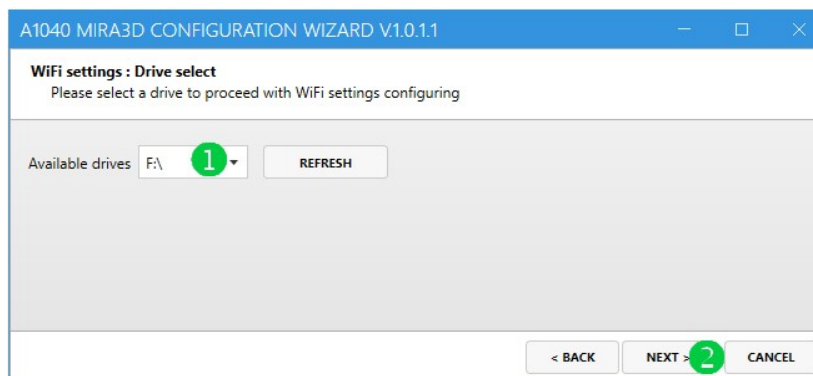

- Select Router/Master (AP-A1040) ①, select European Union region ②, set radio band to 2.4 GHz ③, set WiFi channel at Auto ④ and press "Next" ⑤

IMPORTANT

Use the European Union region for the migration. Later, the operator can reconfigure the WiFi module with the required region.

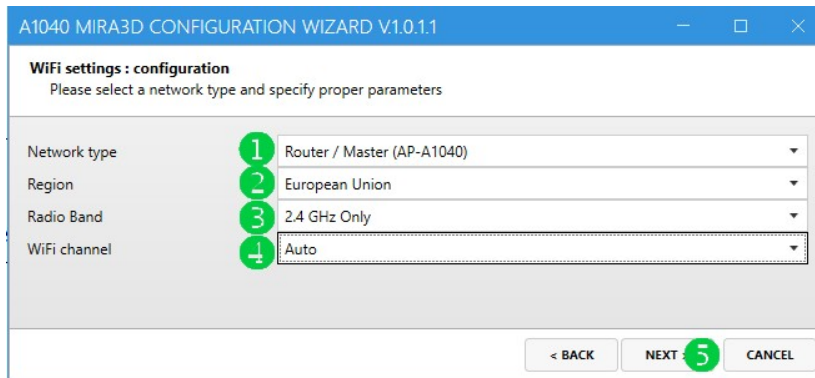

- Check the settings and press "Next" ①

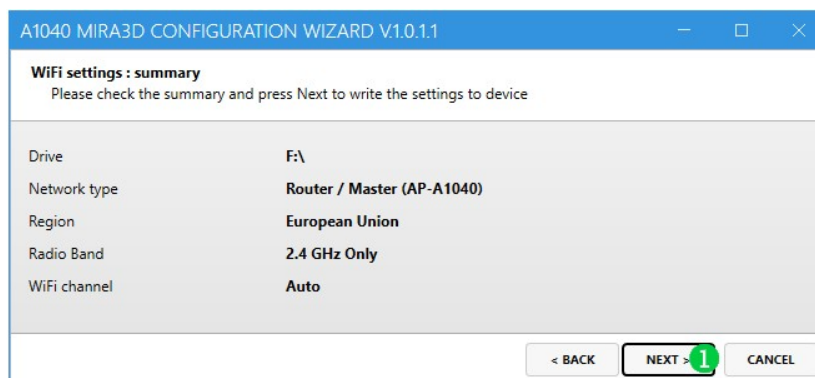

- Wait until LED "UPDATE" stops blinking and press "OK" ① to confirm

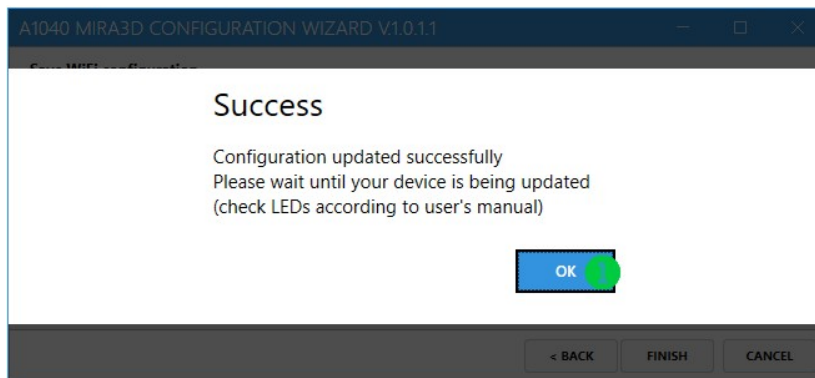

- Press ① close the program

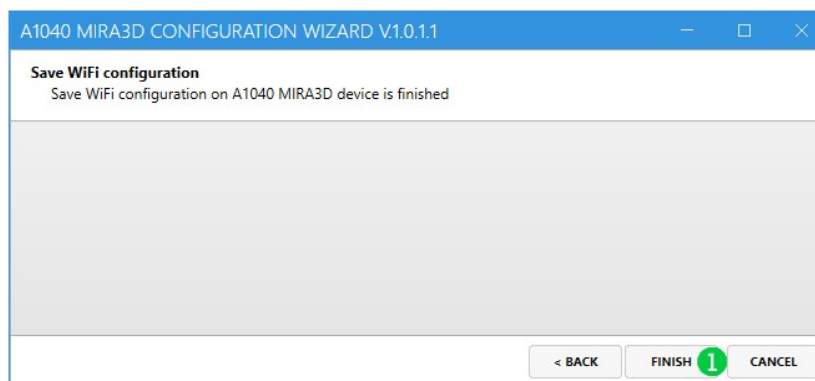

- Disconnect the A1040 MIRA 3D from the PC

-
- Power off the instrument

26 Getting started

26.1 Preparation for work

This chapter describes step-by-step instructions for powering on, preparation for work, and shutting down the instrument.



TUTORIAL-1 and TUTORIAL-2 on the [page](#)¹¹⁶

Powering on the tomograph

- Press and hold the button `power up/down`  for at least 3 seconds. LED "ON" starts blinking. During this time, the tomograph is booting the operating system, please wait. If you are using A1040 MIRA 3D PRO power on both instruments

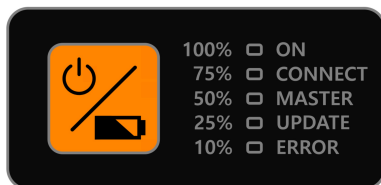

- Soon after powering up, the LED "UPDATE" starts blinking for 10 seconds during the booting, indicating the time slot for the WiFi updating. If you are not planning any updates, please wait. Otherwise, refer to the [page](#)⁸⁵.
- The LED "ON" lights constantly when the booting process is finished, please wait.
- The tomograph is ready to connect with the Tablet-PC. as soon as the LED "CONNECT" is blinking
- Power on the Tablet-PC

Establishing WiFi connection

The A1040 MIRA 3D and A1040 MIRA 3D PRO provide a WiFi network for connection with Tablet-PC; for more information about connectivity, refer to [page](#)⁸⁵. The SSID of the WiFi network has the following pattern AP-A1040MIRA3D-1200XXX, where AP - a shortcut for access point, A1040MIRA3D - the name of the instrument, 1200XXX is the instrument's serial. The last digits XXX are unique for each tomograph.

- Check your master's  serial number on the device sticker. Read mode about the sticker on [page](#)¹⁰.

- Connect the Tablet-PC with the instrument's WiFi AP-A1040MIRA3D-1200XXX where 1200XXX is a serial of the master . The SSID password is 00000000
- Ensure that the connection was successful

Launching the app

- Launch the app, open the setup mode
- Create configuration as it is described on the [page](#) 
- Finalize the configuration and connect to the instrument. If the configuration already exists, the app establishes the connection automatically. The tomograph is ready to work when LED "CONNECT" starts lighting constantly.

Closing the app

- Close the app as any android application
- Switch off or shutdown the Tablet-PC

Power off the tomograph

- Power off the tomograph by pressing and holding power up/down  for 3 seconds.
- During shutting down the instrument starts discharges the transducers. The instrument indicates discharging by simultaneously blinks with all LEDs.

NOTE

In rare cases, the tomograph can be not responding. To shut down the instrument, press and hold  for 10 seconds.

26.2 Update

The system update includes both renewals of the micro-controller firmware and the app. There are two ways to update the app: automatically or manually.

The automatic update is possible if an internet connection and the license server are available. Otherwise, update the app manually.

It is only possible to update the firmware manually.



TUTORIAL-1 and TUTORIAL-2 on the [page](#) 

Automatic app update

- The notification dialog informs the operator about an available app update on the license server.

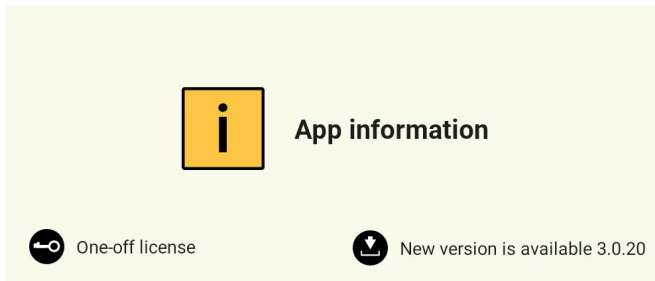

- Press  button (refer to picture 25) to start downloading the installation file.

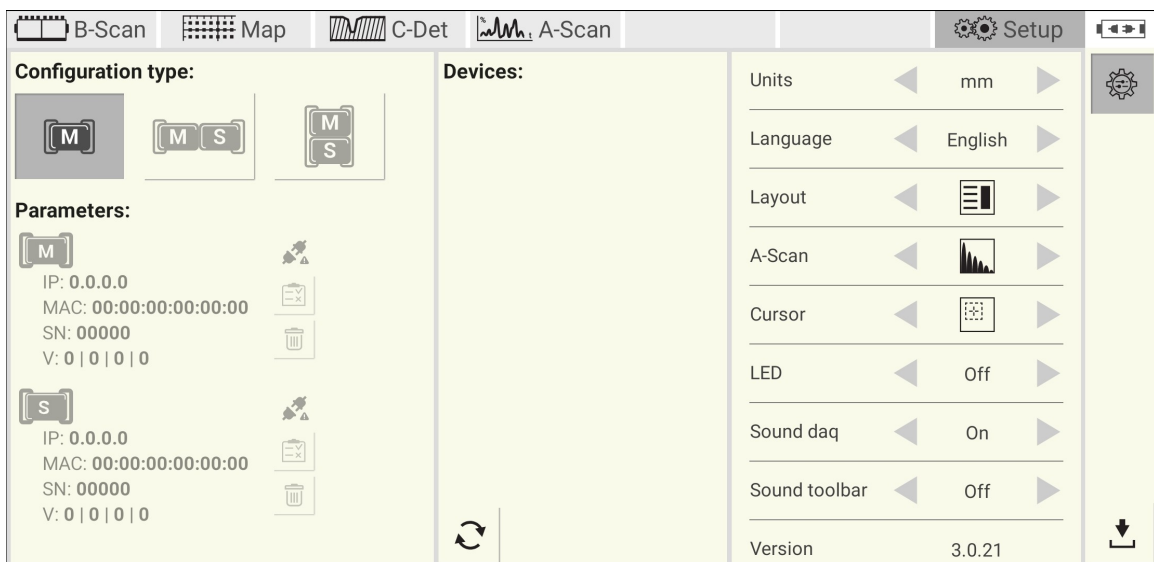
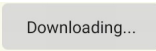

Figure 26: Setup mode with an available app update

- The app indicates the downloading process with .
- The app installation starts automatically after downloading finishes. The installation procedure is similar to the one described on the [page 101](#).
- There is no need to activate the app. The update uses a locally saved license key from the previous installation.

Manual app update

- Download the latest app version from [here](#)
- Install and activate the app. Refer [page 101](#) for installation and [page 102](#) for activation.

Firmware update

- Switch off the instrument

- Download the latest firmware from [here](#)
- Connect the supplied USB cable to the Windows PC TYPE A [plug](#)^[12]
- Press and hold the power button . Within the next 2 seconds, connect the USB cable to the instrument TYPE C [plug](#)^[12]. The UPDATE indicator is on now. It confirms the device's readiness for the update.
- Windows PC detects the A1040 MIRA 3D storage device. Please, open it in the file explorer.

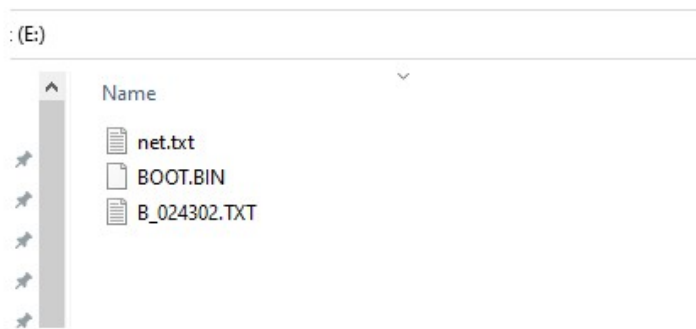

- Copy the new firmware file to the storage. The update indicator is blinking while the firmware file is being copied. Wait until the update indicator stops blinking.
- Disconnect the A1040 MIRA 3D from the PC. The instrument is updated now.
- Power off the instrument

26.3 App installation

This chapter describes the steps for Installation or reinstallation of the Android application manually.



TUTORIAL-4, TUTORIAL-5, TUTORIAL-6, TUTORIAL-7 on the [page](#)^[116]

App uninstalling

In some cases, the operator will need to uninstall the app first. If, for example, the operator forgets to grant required permissions during the installation.

- Uninstall the app
- Delete the app from the trash

Copying installation package to the Tablet-PC

- Download the latest app from here [here](#)

-
- Copy installation package a1040_mira_3d-app-X.X.XX.apk to the `download` folder in the internal storage of the Tablet-PC. The name of `apk` file contains X.X.XX symbols. They are placeholders for the package version.

Starting installation and setting permissions

- Start installation
- Grant all requested permission



WARNING

The application will not function properly until all required permissions have not been granted

-
- Activate the app, refer to the [page](#)^[102]

26.4 App activation

If the app was installed for the first time, reinstalled, or updated manually, it must be activated with a `licensing` key. Check you `warranty certificate` for the [key](#)^[105]. An activation procedure is listed below.



TUTORIAL-4, TUTORIAL-5, TUTORIAL-6, TUTORIAL-7 on the [page](#)^[116]

Activation procedure

- Establish internet connection before starting the app. For internet access one can use either mobile connection or WiFi.



WARNING

Without an internet connection the app activation is not possible

-
- Start the app by tapping on the application icon. The welcome screen presented below appears immediately after start. The app initializes tablet resources while the screen is shown. After initialization is finished the activation dialog starts.

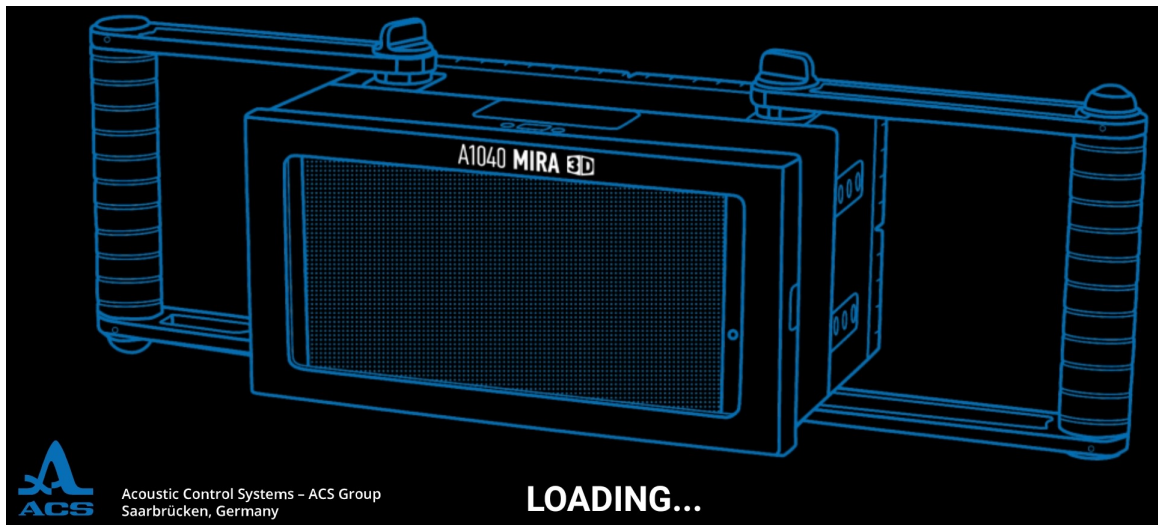

- Enter the license key in the activation dialog and press **1** (Find the license key in the warranty [brochure](#)^[105]). The typing errors while entering the license key can be corrected by using the keyboard. The app will try to verify the license by sending a request to the license server. In case of successful verification, the activation dialog will be closed.

Enter key and activate your app **1** ↵



1	2	3	4	5	6	7	8	9	0	←
Q	W	E	R	T	Y	U	I	O	P	Del
A	S	D	F	G	H	J	K	L	Ins	
Z	X	C	V	B	N	M	◀	▶		

- Grant all requested permission



WARNING

The application will not function properly until all required permissions have not been granted

- Notification dialog informs the operator about the license type  and application status . The dialog can be closed by a single tap.

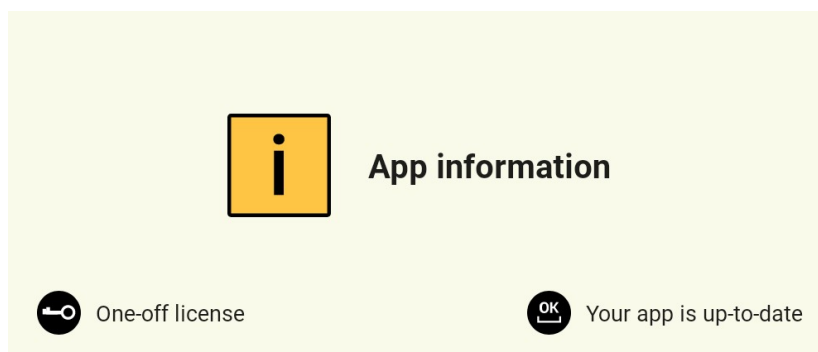

Activation errors

There are several reasons for the activation failure. These are lack of internet connection, a license server error, not existing or not valid license key, or license expiration. Check the status bar  for any error messages:

- Establish an internet connection to activate the app
- The license server is not available, contact the support
- License expired, contact the support
- The license does not exist, contact the support

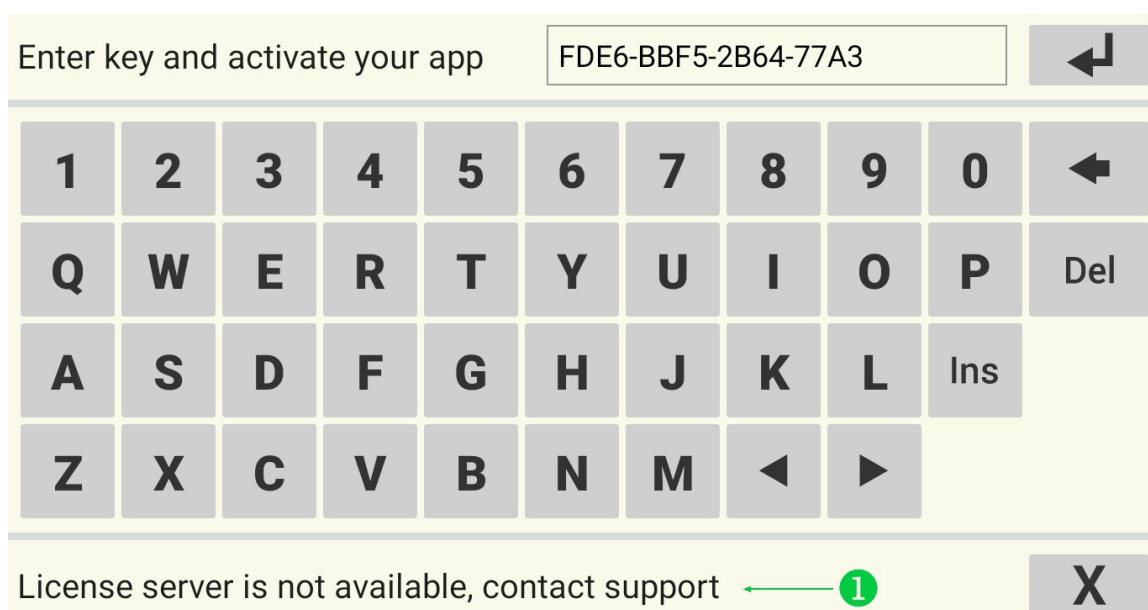

27 Licensing

The application software works with a unique licensing key. The licensing key contains information about the features, functions and serial numbers of the electronic blocks. The licensing key does not allow the application to work with an electronic block with the unknown serial number. Not-activated features and functions will not be available in the application as well.

Licensing key

The user of A1040 MIRA 3D finds the licenses key in the warranty certificate as shown bellow:

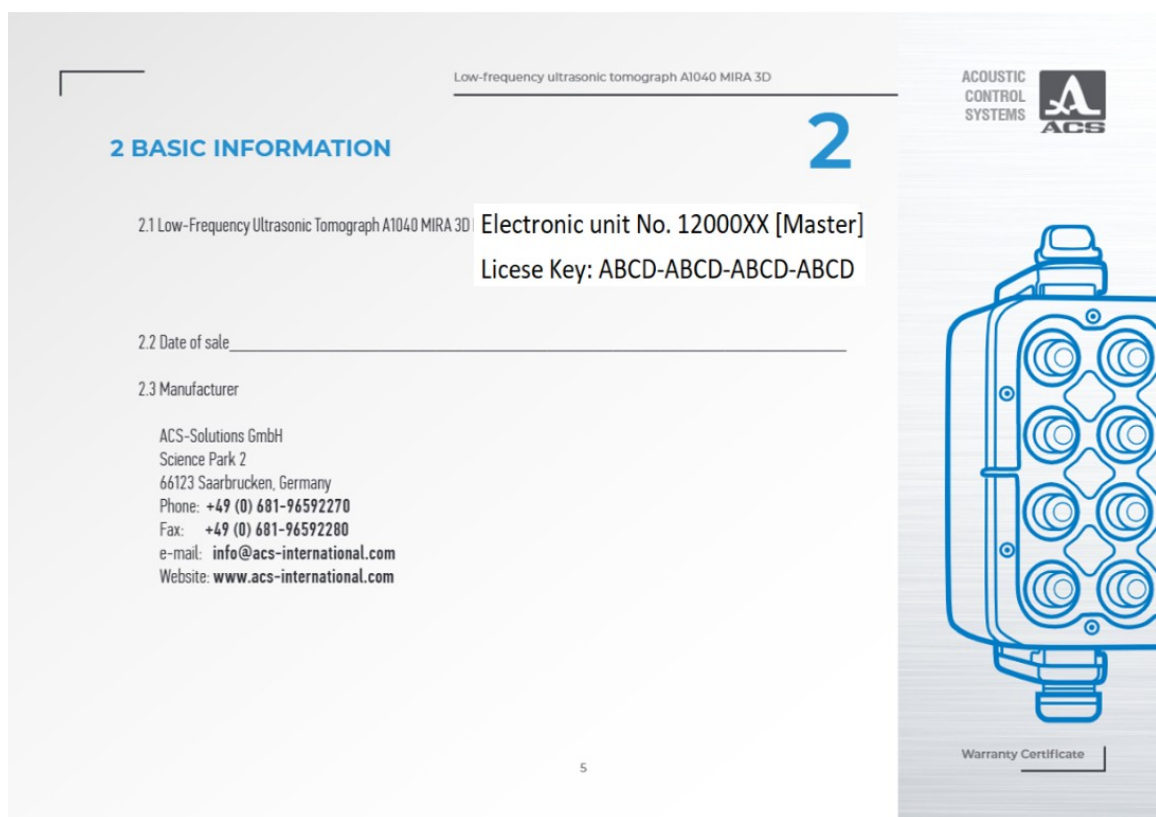

The user of A1040 MIRA 3D PRO finds the licensing key here:

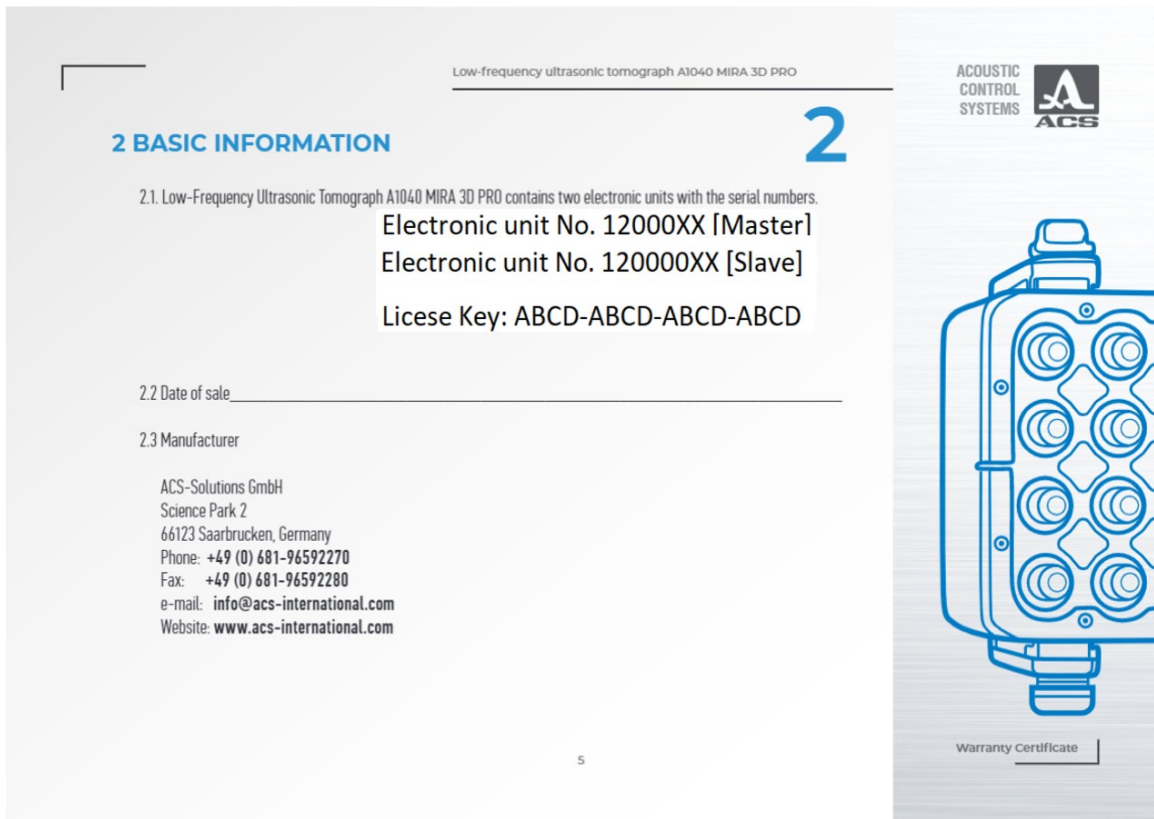

Combinations

The operator can link or unlink electronic units of different A1040 MIRA 3D and A1040 MIRA 3D PRO tomographs to achieve different measurement goals. The A1040 MIRA 3D A can operate in the following combinations with any A1040 MIRA 3D B or any A1040 MIRA 3D PRO C D:

Combination list	License
[A B]	with license [A] or with license [B]
[B A]	with license [A] or with license [B]
[A C]	with license [A] or with license [C D]
[C A]	with license [A] or with license [C D]
[A D]	only with license [A] since [D] is a secondary unit of A1040 MIRA 3D PRO
[D A]	only with license [A] since [D] is a secondary unit of A1040 MIRA 3D PRO

The A1040 MIRA 3D PRO [A B] allows following combinations with any A1040 MIRA 3D PRO [C D]:

Combination list	License
[A C]	with license [A B] or with license [C D]
[C A]	with license [A B] or with license [C D]
[A D]	only with license [A B] since [D] is a secondary unit of A1040 MIRA 3D PRO
[D A]	only with license [A B] since [D] is a secondary unit of A1040 MIRA 3D PRO
[C B]	only with license [C D] since [B] is a secondary unit of A1040 MIRA 3D PRO
[B C]	only with license [C D] since [B] is a secondary unit of A1040 MIRA 3D PRO



CAUTION

The secondary unit [B] of any A1040 MIRA 3D PRO [A B] tomograph can not operate as stand-alone A1040 MIRA 3D.

28 File format

The file format of A1040 MIRA 3D and A1040 MIRA 3D PRO is open for any user. This chapter describes user parameters, reading procedures and saving principles.

28.1 File list

The application saves the data relevant to the measurement in several files placed in the folder named by the user during the save procedure. For different measurement modes the file structure differs.

File/Folder	Description
reporting	The folder contains all files and configurations which are relevant to the report. Find the report in <code>report.pdf</code> file.
config.m3d	main configuration file in JSON format
params.txt	b-scan parameters in ASCII format
raw_data.bin	binary file with raw measured data
soft_data.bin	binary files with reconstructed data
vel_data.bin	This is a binary file with raw velocity data. The application uses this data to estimate the sound velocity.

File params.txt

The application exports the relevant parameters in human-readable ASCII format into a `params.txt` file. Refer to the following table for a detailed description.

Parameter	Description
version : 1.1	The file format may evolve with time. Read the <code>version</code> first. Then adjust your reading routine for that parameter.
analog gain [dB] : 10	refer to page 48
operating frequency [kHz] : 50	refer to page 48
period count : 1.0	refer to page 48
tgc [dB/mus] : 0.00	refer to page 48

tgc delay [mus] : 0	refer to page^[48]
material velocity [m/s] : 2600	refer to page^[48]
dpy delay [mus] : 35	DPY-delay in μ s
filter bandwidth [kHz] : 25	refer to page^[48]
sw compensation : true	refer to page^[48]
compute velocity : true	refer to page^[48]
image : medium	refer to page^[48]
color gain [dB] : 15	refer to page^[48]
frame width [pt] : 928	width of the b-scan in pixels
frame height [pt] : 416	height of the b-scan in pixels
frame count : 21	number of b-scans for <code>array mode = matrix</code>
frame step [mm] : 5.0	distance between b-scan for <code>array mode = matrix</code>
frame left [mm] : -1116.00	left border of the b-scan in mm
frame right [mm] : 1115.00	right border of the b-scan
frame top [mm] : 0.00	upper border of the b-scan
frame bottom [mm] : 1000.00	lower border of the b-scan
computed velocity [m/s] : 2860	estimated sound velocity
computed delay [smp] : 30	DPY-delay in samples
(1,1) computed velocity [m/s] : 1370	Estimated sound velocity for a map position (X,Y), refer to page^[111] . This parameter exists only in the <code>map</code> mode.
(1,1) computed delay [smp] : 35	DPY-delay in samples for a map position (X,Y), refer to page^[111] . This parameter exists only in the <code>map</code> mode.

File raw_data.bin

Read more about raw_data.bin on [page^{\[111\]}](#).

File soft_data.bin

The size of reconstructed data depends on the `array mode` parameter. In the case of `array mode = linear`, the file includes one reconstructed b-scan (or one

slice). However for `array mode = matrix` the file contains several b-scans. These b-scans form a resulting volume. Use the following `matlab` code for reading:

```
clear all;
param.frame_width = 928;
param.frame_height = 416;
fpath = '../saft_data.bin';
finfo = dir(fpath);
filesize = finfo.bytes; %get files size in bytes
fid = fopen(fpath, 'r', 'l');
bscan = fread(fid, 'single');
fclose(fid);
if(filesize == param.frame_width * param.frame_height *
4)
%array mode = linear, instrument configuration = A1040
MIRA 3D / A1040 MIRA 3D PRO
    T =
reshape(bscan,param.frame_width,param.frame_height); %
read b-scan
else %array mode = matrix, instrument configuration =
A1040 MIRA 3D / A1040 MIRA 3D PRO
    n = filesize/
(param.frame_width*param.frame_height)/4; %read b-scan
    T =
reshape(bscan,param.frame_width,param.frame_height,n);
end
```

NOTE

Read `frame_width` and `frame_height` parameters values from `param.txt`

File `vel_data.bin`

The size of the velocity data depends on `array mode` parameter. Read the `vel_data.bin` using the following code:

```
clear all;
fpath = '../vel_data.bin'; %define file path
finfo = dir(fpath);
filesize = finfo.bytes; %get files size in bytes
fid = fopen(fpath, 'r', 'l');
bscan = fread(fid, 'int16');
fclose(fid);
if(filesize == 4096 * 28 * 2) %array mode =
linear/matrix, instrument configuration = A1040 MIRA 3D
    a1040_mira3d_bscan_linear = reshape(bscan,4096,28)';
%read and reshape 28 vectors
```

```
elseif(filesize == 4096 * 120 * 2) %array mode =
linear/martix, instrument configuration = A1040 MIRA 3D
PRO
    a1040_mira3d_pro_bscan_liner =
reshape(bscan,4096,120)'; %read and reshape 120 vectors
end
```

28.2 Modes

B-Scan mode

For the data measured in `b-scan` mode the saved data folder contains the files described on [page 108](#).

C-Det mode

The file structure of a measurement in `c-det` mode is the same as for `b-scan` mode.

MAP mode

The data saved for a map mode measurement has slightly different file structure. It contains `reporting` folder, `config.m3d`, `params.txt` files and several subfolders named in `X_Y` format, where `X = 1,2,...` and `Y = 1,2,...`. Each `X_Y` subfolder contains `raw_data.bin`, `saft_data.bin` and `vel_data.bin` files, which are raw, reconstructed and velocity data for the corresponding map position.

NOTE

In the map mode the file `params.txt` contains estimated sound velocity and DPY-dealy for each map position. These entries start from `(X, Y)`.

28.3 Raw data

File `raw_data.bin`

The procedure for reading of `raw_data.bin` depends on `array mode` [parameter 98](#) (linear or matrix) and `instrument configuration` [type 72](#). Use the following `matlab` code for reading:

```
clear all;
fpath = '../raw_data.bin'; %define file path
finfo = dir(fpath);
filesize = finfo.bytes; %get files size in bytes
fid = fopen(fpath, 'r', 'l');
bscan = fread(fid, 'int16');
fclose(fid);
```

```
if(filesize == 4096 * 28 * 2) %array mode = linear,
instrument configuration = A1040 MIRA 3D
    a1040_mira3d_bscan_linear = reshape(bscan,4096,28)';
%read and reshape 28 vectors
elseif(filesize == 4096 * 496 * 2) %array mode = matrix,
instrument configuration = A1040 MIRA 3D
    a1040_mira3d_bscan_matrix = reshape(bscan,4096,496)';
%read and reshape 496 vectors
elseif(filesize == 4096 * 120 * 2) %array mode = linear,
instrument configuration = A1040 MIRA 3D PRO
    a1040_mira3d_pro_bscan_liner =
reshape(bscan,4096,120)'; %read and reshape 120 vectors
elseif(filesize == 4096 * 2016 * 2) %array mode = matrix,
instrument configuration = A1040 MIRA 3D PRO
    a1040_mira3d_pro_bscan_matrix =
reshape(bscan,4096,2016)'; %read and reshape 2106 vectors
end
```

A1040 MIRA 3D, mode = linear

Before working with raw data refer to [chapter 65](#) for recalling how the linear mode of A1040 MIRA 3D works. Read data saved in `raw_data.bin` file using code above. The read array `a1040_mira3d_bscan_linear` has 28 vectors. For the indexing scheme of the vectors refer to the next table:

Array index	Transmitters	Receivers
1	[1.1], [1.2], [1.3], [1,4]	[2.1],[2.2],[2.3],[2.4]
2		[3.1],[3.2],[3.3],[3.4]
3		[4.1],[4.2],[4.3],[4.4]
4		[5.1],[5.2],[5.3],[5.4]
5		[6.1],[6.2],[6.3],[6.4]
6		[7.1],[7.2],[7.3],[7.4]
7		[8.1],[8.2],[8.3],[8.4]
8	[2.1], [2.2], [2.3], [2,4]	[3.1],[3.2],[3.3],[3.4]
9		[4.1],[4.2],[4.3],[4.4]
10		[5.1],[5.2],[5.3],[5.4]
11		[6.1],[6.2],[6.3],[6.4]
12		[7.1],[7.2],[7.3],[7.4]
13		[8.1],[8.2],[8.3],[8.4]
...
28	[7.1], [7.2], [7.3], [7,4]	[8.1],[8.2],[8.3],[8.4]

A1040 MIRA 3D, mode = matrix

Before working with raw data refer to [chapter 65](#) for recalling how the matrix mode of A1040 MIRA 3D works. Read data saved in `raw_data.bin` file using code above. The array `a1040_mira3d_bscan_matrix` contains 496 vectors. For the indexing scheme of the vectors refer to the next table:

Array index	Transmitters	Receivers
1	[1.1]	[2.1]
2		[3.1]
...		...
7		[8.1]
8		[1.2]
9		[2.2]
...		...
15		[8.2]
..		...
31		[8.4]
32		[2.1]
33	[4.1]	
..	..	
63	[8.4]	
64	[3.1]	[4.1]
...
496	[7.4]	[8.4]

A1040 MIRA 3D PRO, mode = linear

Before working with raw data refer to [chapter 10](#) for recalling how the linear mode of A1040 MIRA 3D PRO works. Read data saved in `raw_data.bin` file using code above. The array `a1040_mira3d_pro_bscan_linear` has 120 vectors. For the indexing scheme of the vectors refer to the next table:

Array index	Transmitters	Receivers
1	[1.1], [1.2], [1.3], [1,4]	[2.1],[2.2],[2.3],[2.4]
...		...
15		[8.1],[8.2],[8.3],[8.4]
16	[2.1], [2.2], [2.3], [2,4]	[3.1],[3.2],[3.3],[3.4]
...
120	[15.1], [15.2], [15.3], [15,4]	[16.1],[16.2],[16.3],[16.4]

A1040 MIRA 3D PRO, mode = matrix

Before working with raw data refer to [chapter 68](#) for recalling how the linear mode of A1040 MIRA 3D PRO works. Read data saved in `raw_data.bin` file using code above. The array `a1040_mira3d_pro_bscan_linear` has 2016 vectors. For the indexing scheme of the vectors refer to the next table:

Array index	Transmitters	Receivers
1	[1.1]	[2.1]
2		[3.1]
...		...
63		[16.4]
64	[2.1]	[3.1]
...
125		[16.4]
...
2016	[15.4]	[16.4]

29 Downloads

29.1 Tutorials

TUTORIAL ID	Description	Link
TUTORIAL-1	Getting started for HONOR X10	download
TUTORIAL-2	Getting started for LG V60	download
TUTORIAL-3	Migration from Hotspot to WiFi	download
TUTORIAL-4	App installation	download
TUTORIAL-5	App license activation	download
TUTORIAL-6	App re-installation	download
TUTORIAL-7	App uninstalling	download

29.2 Files

FILE ID	Description	Link
FILE1	A1040MIRA3D_wlan_configuration.zip contains A1040MIRA3D_wlan_configuration.exe utility and latest firmware for the wifi module.	download

30 Instrument tuning

This chapter describes the features of instrument setup and an approach for parameter tuning.

30.1 Analog gain

Analog gain regulates (increases or decreases) the analog signal amplitude before being transformed into a digital signal by ADC (analog-digital converter). Analog gain units are decibels (dB). It is essential to adjust the analog gain every time before you start working with a new object. Too high analog gain leads to ADC overflow error and may cause severe distortions in the image synthesis procedure. The low analog gain suppresses the useful amplitudes and increases quantization and thermal noise. Apply the following procedure to adjust the analog gain.

Analog gain adjusting procedure

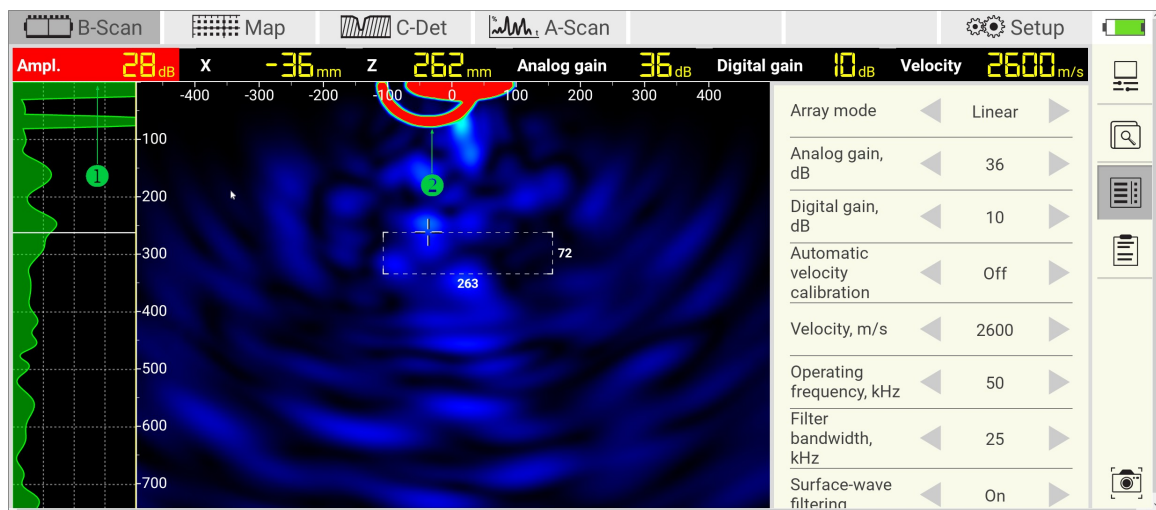

Step	Description
1	Create an online B-Scan measurement with default parameters, refer for the details to the page 52 . Take a B-scan. If the amplitude indicator ① has black background (i.e. no ADC overflow registered), go to step 2. If the amplitude indicator has red background (as in the picture), this means ADC overflow is recorded. In this case go to step 3. The amplitude overflow on the B-Scan is easily recognizable by red circular lines ② (red stands for the maximal amplitude).
2	Increase the analog gain step by step. For each gain value, take the B-Scan. Stop when the indicator turns to red. This means the ADC overflow is being registered. Decrease the analog gain by 6-8 dB to avoid ADC overflow during the whole measurement on the spacemen. Use the adjusted analog gain to scan the object.
3	Decrease the analog gain step by step. For each gain value, take the B-Scan. Stop when the indicator turns to black. Go to step 2.

30.2 Time gain compensation

Time gain compensation (further TGC) is the ADC's (analog-digital converter) feature, that increases signal analog gain with time. The TGC units are decibels per microseconds ($\text{dB}/\mu\text{s}$). The correct usage of TGC may lead to reducing of quantization and thermal noise. Another benefit of TGC is compensation of ultrasound attenuation caused by the material structure. The TGC delay defines the start time when TGC applies. The TGC delay units are μs (microseconds).

Show TGC and TGC curve slope

The operator may show the TGC curve ① by setting Show TGC = on ②, refer to chapter on [page 48](#). The slope of the TGC curve may be adjusted with ③.

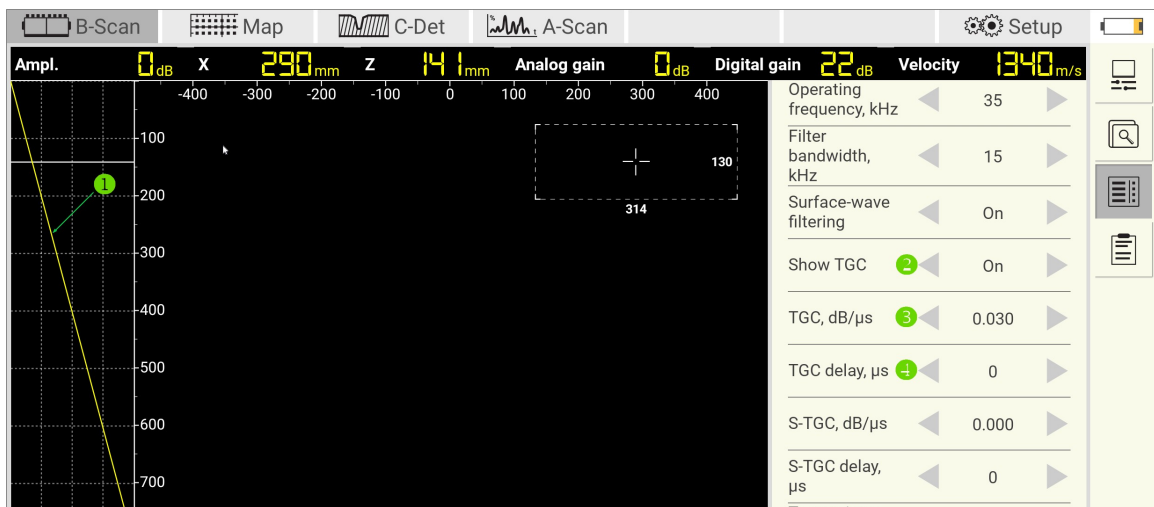

TGC delay

Use the TGC delay **4** to shift the beginning of the TGC curve later in time (s. beginning of the TGC curve **5**). Since the compensation of the gain doesn't apply before the TGC delay, it will be possible to equalize the energies of the back wall and the near-surface reflector. The next figure shows an example the TGC delay = 200 μ s

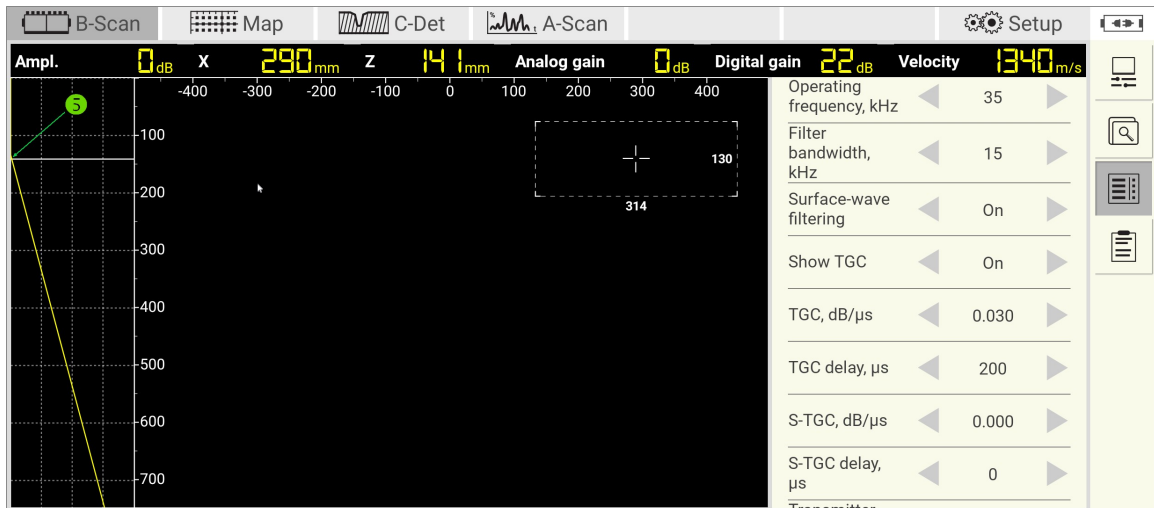

Adjustment of analog gain and TGC

Analog gain and TGC curve are interdependent. The increase of Analog gain may lead to the reduction of the dynamic range of the TGC. The following figure introduces an example with a non-zero Analog gain. In this case, the TGC curve has two constant value sections. The first section **1** corresponds to the value of the Analog gain. The second section **2** shows the gain curved reached its maximal value. It is good practice to start with Analog gain = 0 dB, trying to avoid constant value sections of the TGC curve. If necessary increase the analog gain and adjust the TGC curve. In case of overflow (refer to [page 117](#) for more information) reduce the analog gain and readjust the TGC curve.

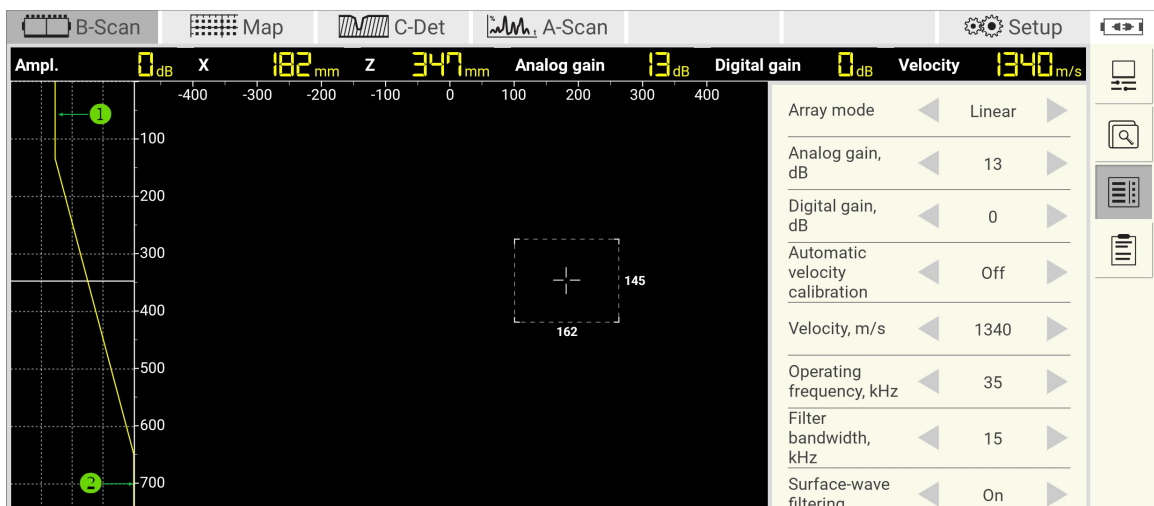

Example

The following figures show work of the TGC. The first one shows data with $TGC = 0.000 \text{ dB}/\mu\text{s}$. The back wall amplitude ① is ca. 9 dB less than the amplitude of the reflector ② (consider A-scan ③ for reference).

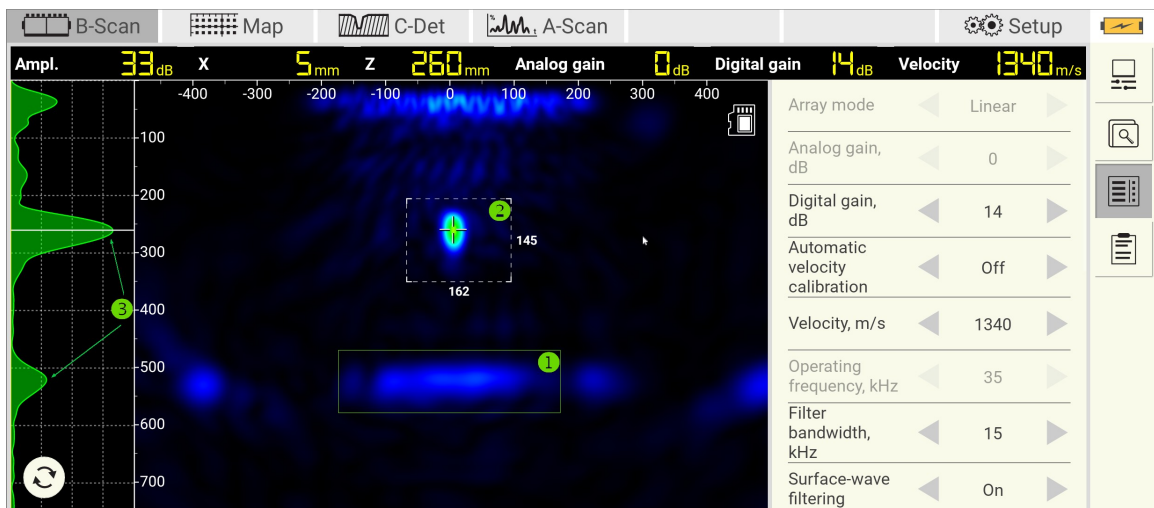

The following figure shows that $TGC = 0.026 \text{ dB}/\mu\text{s}$ equalizes the back walls' and the reflectors' amplitudes.

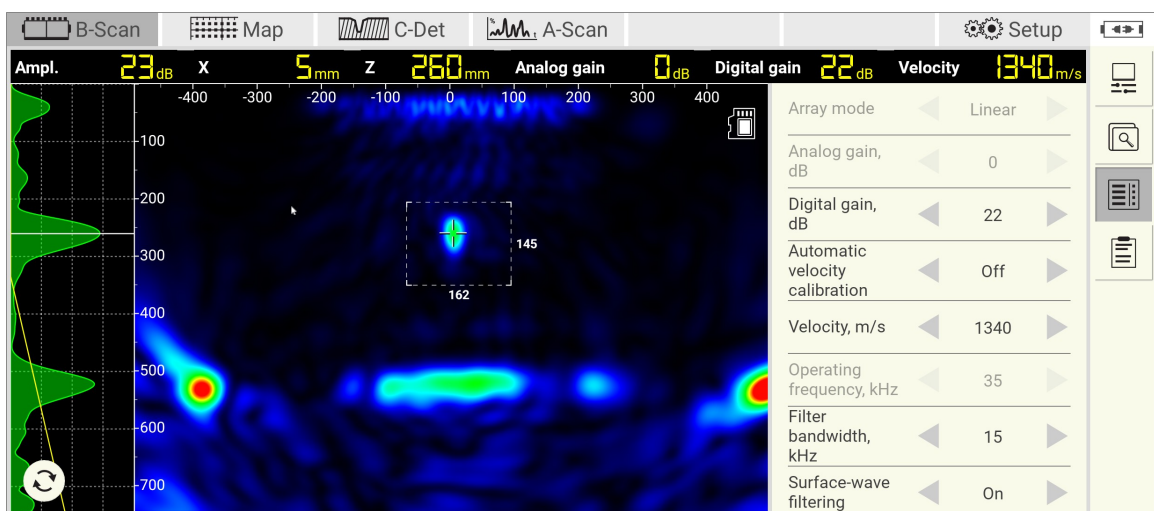

30.3 Software time gain compensation

Software time-gain compensation (further S-TGC) works similar to TGC, refer to the [page 118](#). The S-TGC operates with signals at the ADC output (i.e. digitized signals). The S-TGC delay takes values from 0 μs to 500 μs and S-TGC from -1 to 1 dB/ μs . The negative values of S-TGC help to correct not optimal TGC choice. You can apply S-TGC in the offline mode for already saved data.

30.4 Operating frequency

The `Operation frequency` parameter defines the frequency of the pulse applied to the DPC-transducer. The bandwidth of the DPC-transducer ranges between 10 and 100 kHz. The central DPC-frequency 50 kHz is a good start value. Increase the frequency while working with thicknesses less than 200 millimeters. To evaluate specimens thicker than 500 millimeters work within the 35-50 kHz range. If your focus of concern is about the near-surface area, use 50-100 kHz range.

Wavelength and Resolution

Use the following equation to estimate the wavelength λ :

$$\lambda = \frac{v}{f},$$

where v and f stand for ultrasonic velocity and frequency. The higher the frequency is shorter the wavelength will be. A shorter wavelength yields a higher resolution. However, the ultrasound wave of a larger wavelength exhibits lesser attenuation and propagates deeper.

Operation frequency optimization

Try to make the best choice for `Operation frequency` parameter before getting into the measurements. Do it experimentally by varying the frequency starting at 50 kHz. The following figure shows the data taken at `Operation frequency` = 40 kHz. The first ①, second ②, and third back-wall ③ echos are good recognizable.

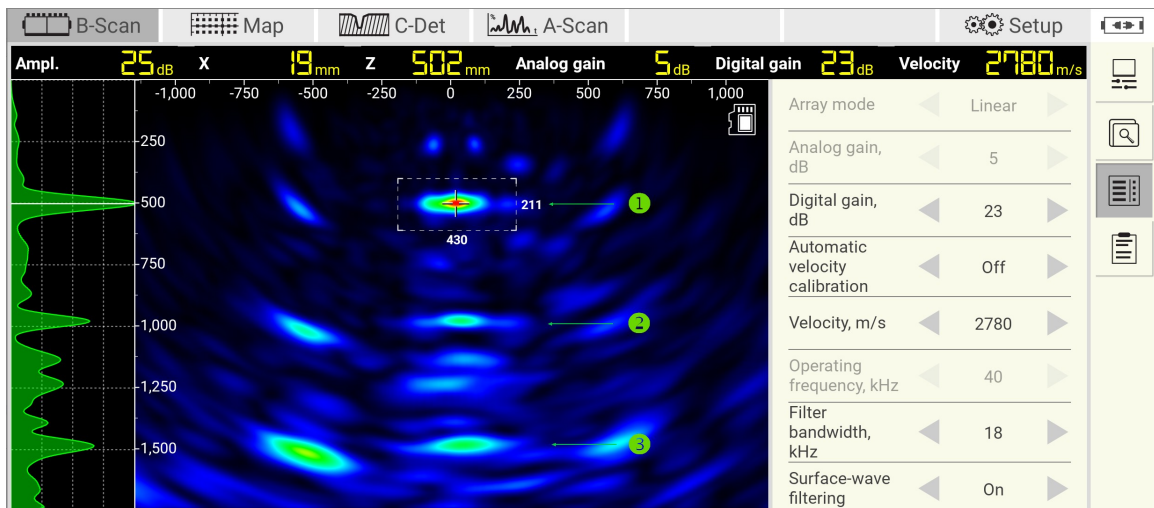

Increasing the `Operating frequency` up to 60 kHz leads to the degradation of the penetration depth (back-walls ② and, in particular, ③ almost disappear). At the same time, the signals from rebars ④ at 60 kHz have higher amplitude (sensitivity) than at 40 kHz. At 60 kHz the amplitude rises to 5 dB.

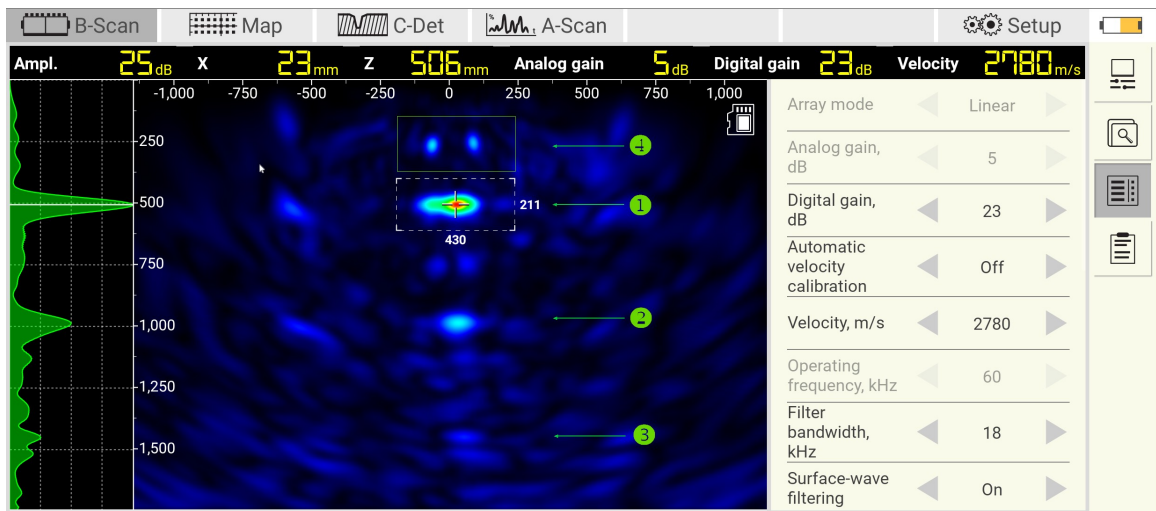

Depending on the inspection task objective, either depth or resolution, decide on a strategy for Operation frequency choice.

30.5 Transmitter pulse sequence

The Transmitter pulse sequence (in the following TPS) is the number of periods of the excitation pulse. TPS takes the following values {0.5, 1, 1.2,... 9.5, 10}. Using a long sequence to increase transmitting energy is a well-known approach. However, keeping in mind the inhomogeneous properties of the concrete, it would be rather inappropriate to recommend a certain TPS value. The TPS may vary with different concrete types. Estimate the optimal TPS for each task, starting with TPS = 0.5.

The following figure shows a B-SCAN taken at the highly dispersive sample with TPS = 0.5. The first back wall ① is well recognizable. The second back wall vanishes.

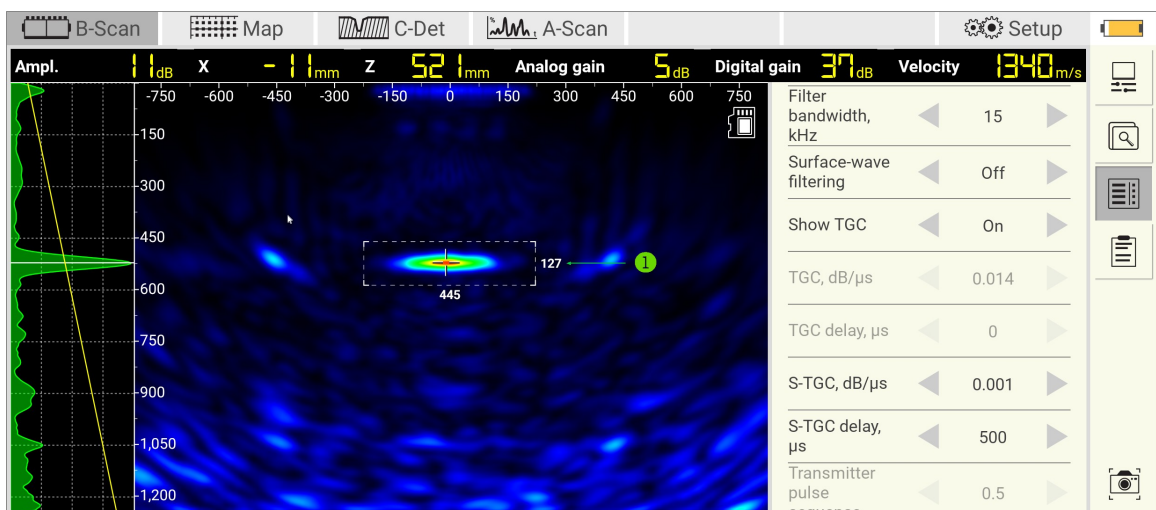

By setting the TPS to 3.5, the second back wall ② becomes visible. The signal is noisy, and the shape of ② the indication changes with every new measurement with the same parameters.

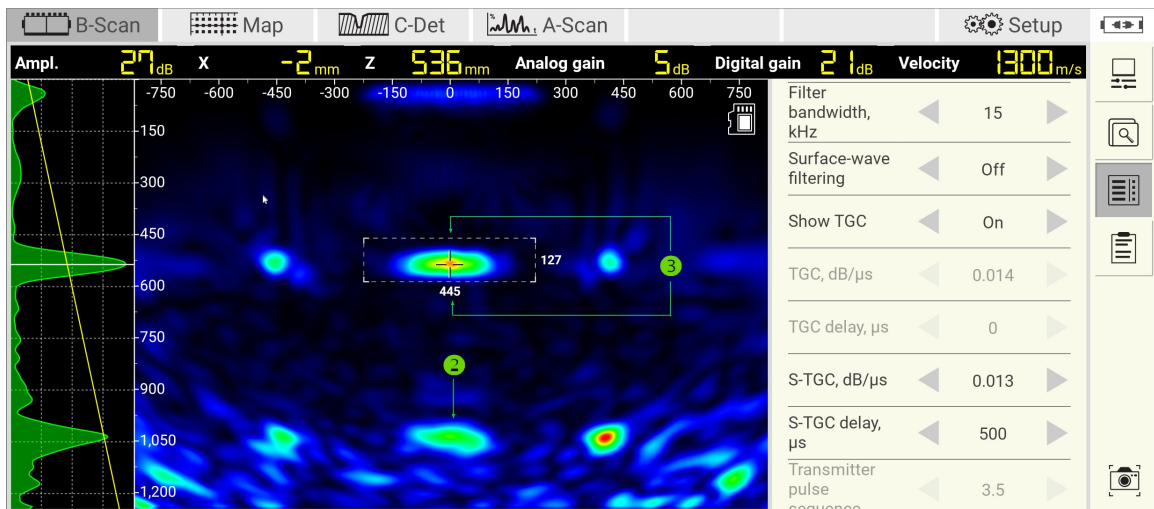

The resolution of the latter image is getting coarse ③. The shape of the first back wall exhibits widening in the depth direction. However, the increase in TPS positively affects the signal-to-noise ratio. The further increment of the TPS length makes the resolution more coarse (see the picture below).

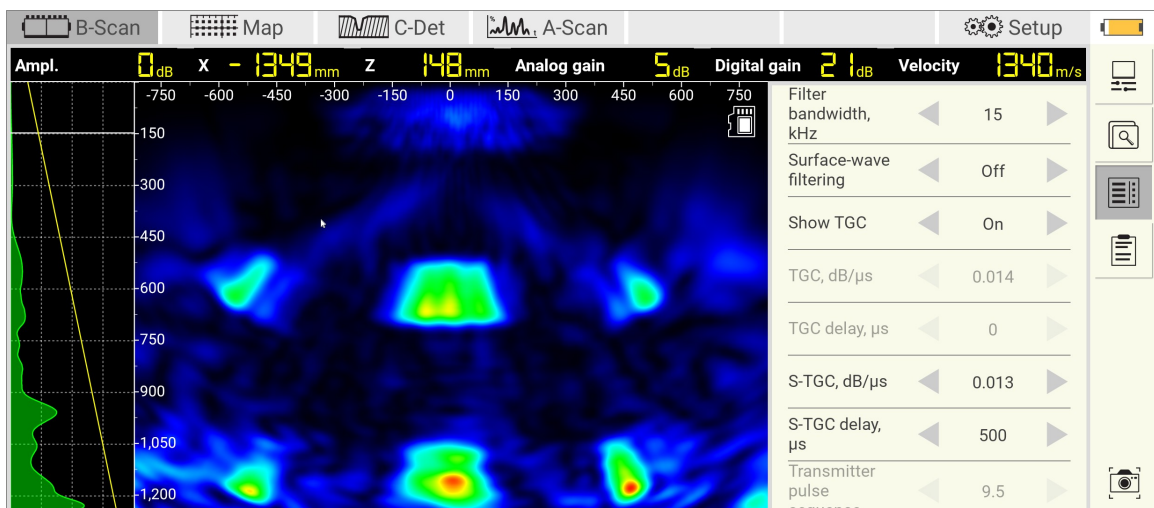

Thus, choosing TPS is the tradeoff between the resolution and the sensitivity.

30.6 Velocity calibration

The knowledge about the sound velocity (later velocity) is essential for successful concrete inspection and evaluation. The false velocity may crucially impact the image synthesis. It may cause image distortions leading to misinterpreting the results. Use one of the following methods or their combination for velocity estimation.

Method 1: Known sample thickness

In various applications, the thickness of the inspected sample is known. Measure the velocity as follows:

- Set the Automatic velocity calibration = off ①, and adjust the Velocity ② between 2500–2900 m/s (typical transverse ultrasonic velocity). Finalize the adjustments by pressing any data collection button.
- Set the cursor ③ on the first back wall and read the depth indicator ④.
- Increase or decrease the Velocity until the indicator shows the thickness of the sample.
- Repeat the procedure to ensure that the estimated thickness is stable

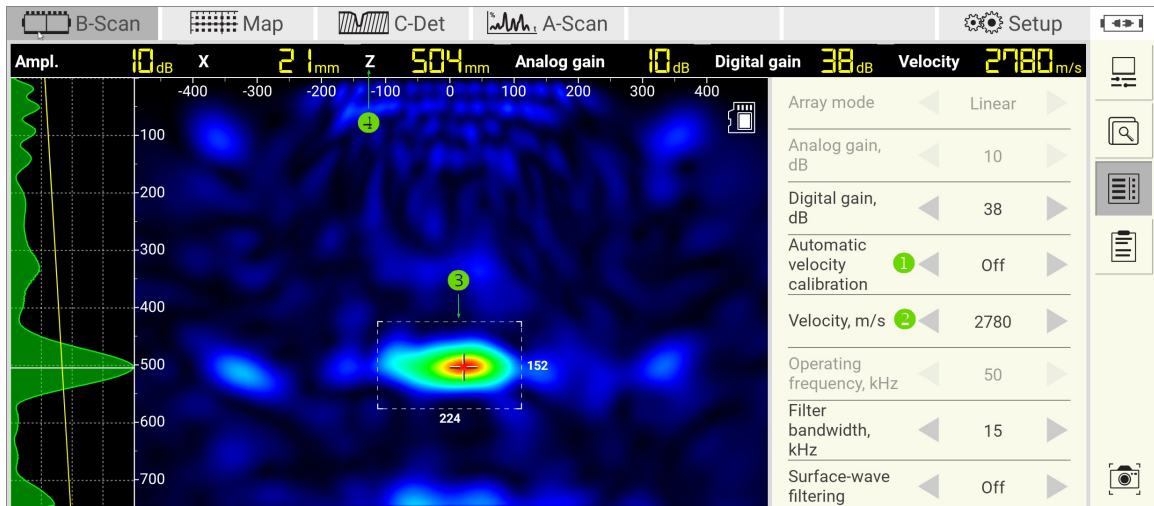

NOTE

If the thickness of inspected area is not known, use the part of the object with known thickness for the velocity calibration. Set the estimated velocity for the primary measurements. While working with rough surfaces, estimate the velocity at several points, and use the average for the measurements.

Method 2: Automation velocity calibration

The A1040 MIRA 3D and A1040 MIRA 3D PRO may estimate the sample velocity using ultrasonic wave propagating along the surface, from one DPC sensor to another. The surface velocity may differ from volume velocity (velocity estimated using the backwall). However, the surface velocity gives a good guess to start the measurements:

- Set the Automatic velocity calibration = on ①. Finalize the adjustments by pressing any data collection button. Read the estimated velocity from the indicator ②
- Repeat the procedure to ensure that the velocity is stable

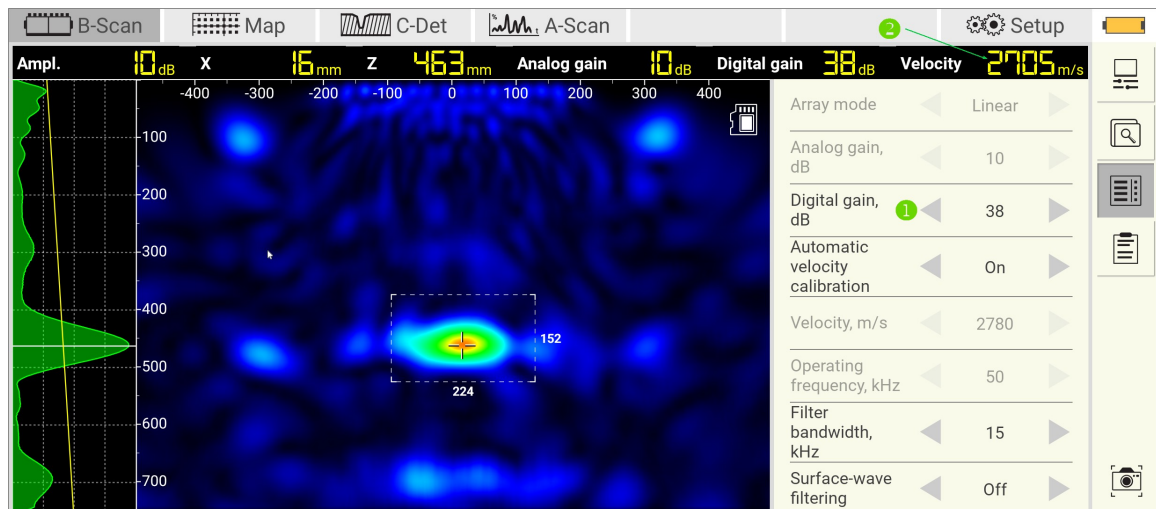

NOTE

While working with rough surfaces, estimate the velocity at several points, and use the average for the measurements.

30.7 E-Boosting

The attenuation characteristics of cement-based material components, including paste, aggregate, voids, and rebars, may influence the energy of the ultrasonic signals. The energy of the digital and the thermal noise often overcomes the signal. The e-boosting technology utilizes innovative transmitting principles increasing the signal's energy. We recommend using the e-boosting in case the registering of the back wall due to high attenuation fails (both thick and thin samples).

NOTE

The E-boosting feature is unavailable by default. Order the E-boosting license over info@acs-international.com. After order confirmation, uninstall and install the app; refer to the app [installation](#)^[102] and [activation](#)^[101] chapters for details. The E-boosting will become available after online license activation. Both instruments A1040 MIRA 3D and A1040 MIRA 3D PRO support the E-Boosting feature.

E-Boosting parameters

If the E-Boosting feature is active, the following parameters become available:

Parameter	Description
Depth	The range of the <code>Depth</code> gets extended. The operator may set it up to 8 meters now. Read more about the <code>Depth</code> parameter in the chapter on the page^[72] .
Zoom	The range of the <code>Zoom</code> gets extended. The operator may set its value to 4000, 4500,...,9000 mm. Read more about the <code>Zoom</code> parameter in the chapter on the page^[50]
E-Boosting	<code>E-boosting</code> parameter is available in the <code>Main parameters</code> tab refer to the page^[48] . Use <code>off</code> to switch off the e-boosting feature. Switch between <code>Weak</code> / <code>Medium</code> / <code>Strong</code> options. The <code>Weak</code> option may keep the minor defects but reduce the noise lesser the <code>Strong</code> . And otherwise choosing <code>Strong</code> may smooth the minor flaws but reduces the noise better than the <code>Weak</code> option.

How to use E-Boosting

Step	Description
1	Switch off the E-Boosting (<code>E-Boosting = off</code>), estimate the average velocity. Refer the velocity calibration chapter on the page^[123] for more details.
2	Switch on the E-Boosting, start with <code>E-Boosting = Strong</code>
3	Set the <code>Analog gain = 0 dB</code> . Check the overflow indicator at every take. The overflow is not allowed. For more information refer to the page^[117]
4	Optimize the operation frequency. Start with <code>Operation frequency = 35 KHz</code> and <code>Filter bandwidth = 15 KHz</code> . You will find the frequency optimization procedure on the page^[121]
5	Set the <code>Depth</code> parameter appropriate to the task.
6	Set the <code>Zoom</code> parameter appropriate to the task
7	Adjust TGC. Start with <code>TGC = 0.01 dB/μs</code> and <code>TGC delay = 0 μs</code> ; If necessary, refer to the details on the page^[118]
9	Take a B-Scan. If the back wall is still not recognizable or you do not see any defects, conduct fuhrer optimization of parameters.

Results

The following figure shows the B-Scan measured on a sample of high attenuation properties. The first **1** and second **2** back wall signals are well distinguishable. The third back wall signal **3** is drowned in noise.

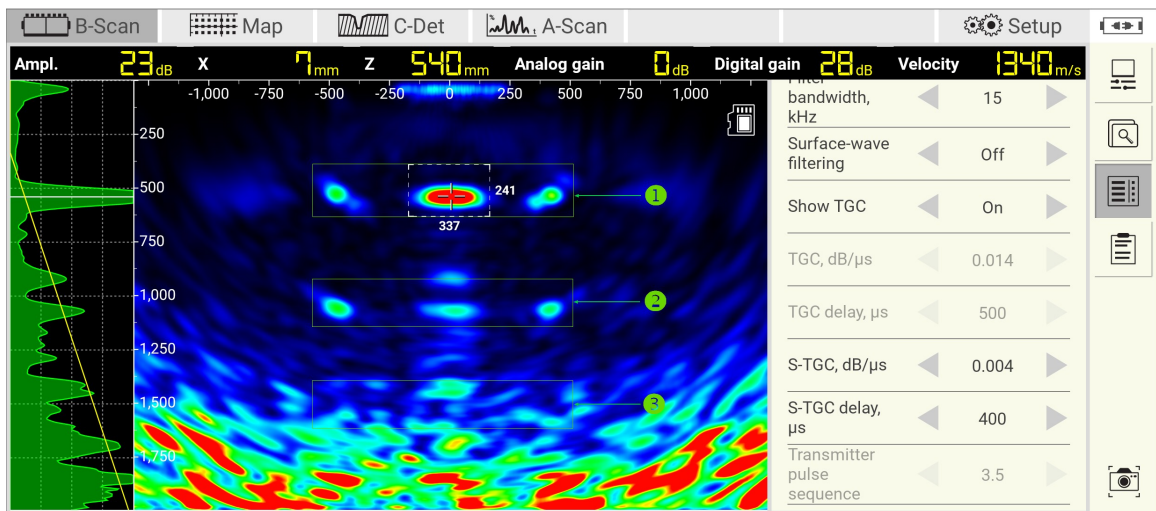

Applying the E-Boosting reduces the digital and thermal noise starting from 1,5 meters. The third back wall signal ③ is clean and well recognizable.

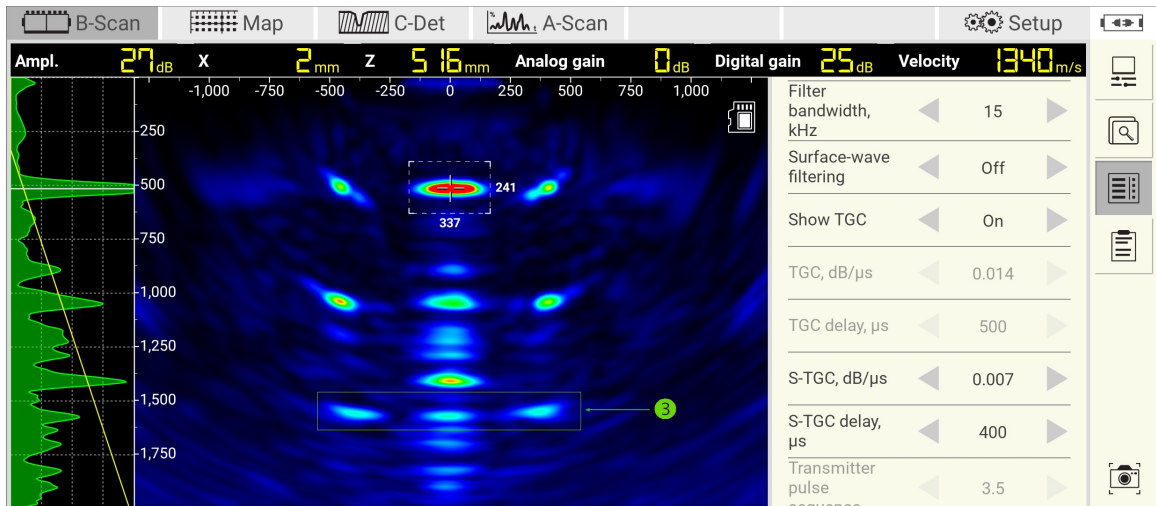

In this particular case, even the fourth back wall signal ④ begins to reveal itself.

